

NT90 (T90)



30.5 × 24.2 × 17 32.5 × 27.6 × 20.5

COC 03001003503

UL E160644

R50126373

Features

- Small size, light weight.
- Low coil power consumption, heavy contact load.
- Strong anti-shock and anti-vibration, high reliability, long life.
- PC board mounting.
- Suitable for automobile, machine, electronic equipment, air conditioner and household appliances applications.

Ordering Information

NT90 R H A S DC12V C B 0.9
 1 2 3 4 5 6 7 8 9

1 Part number: NT90(T90)	6 Coil rated voltage(V): AC:12,24,110,120,220 DC:3,5,6,9,12,15,18,24,48,110
2 Terminal: R: without Pin6; NIL: With Pin6	
3 Load: H:30A; N:40A	7 Contact material: C: AgCdO; S: AgSnO ₂
4 Contact arrangement: 1A:1A; 1B:1B; 1C:1C	8 Resist heatclass: B:130°C F:155°C
5 Enclosure: S: Sealed type; D: Dust cover; E: Covered; O: Open type	9 Coil power consumption: 0.6:0.6W; 0.9:0.9W NIL:2VA

Contact Data

Contact Arrangement	1A (SPSTNO) 1B(SPSTNC) 1C(SPDT(B-M))
Contact Material	AgCdO AgSnO ₂
Contact Rating (resistive)	NO:30A/240VAC,14VDC; NC:20A/240VAC;30A/14VDC NO:40A/240VAC,30VDC; NC:30A/240VAC,30VDC (0.9W) NO:30A/277VAC;NC:20A/277VAC Motor load: NO:2HP 250VAC; NC:1.5HP 250VAC Lamp load: TV-5 5A/280VAC(Ballast)
Max. Switching Power	1100W 7200VA
Max. Switching Voltage	110VDC 300VAC Max. Switching Current:40A
Contact Resistance or Voltage drop	≤ 30mΩ Item 4.12 of IEC 61810-7
Operation life	Electrical 10 ⁵ Item 4.30 of IEC 61810-7
	Mechanical 10 ⁷ Item 4.31 of IEC 61810-7

Coil Parameter

Dash numbers	Rated voltage VAC		Rated current mA	Coil resistance Ω ± 10%	Pick up voltage VAC(max) (75%of rated voltage)	Release voltage VAC(min) (30%of rated voltage)	Coil power	Operate Time ms	Release Time ms
	Rated	Max							
012AC	12	15.6	187	27	9.0	3.6	2VA	—	—
024AC	24	31.2	95	120	18.0	7.2			
110AC	110	143	20	2360	82.5	33.0			
120AC	120	156	16.5	3040	90.0	36.0			
220AC	220	286	6.4	13490	165.0	66.0			

CAUTION: 1.The use of any coil voltage less than the rated coil voltage will compromise the operation of the relay.
 2.Pickup and release voltage are for test purposes only and are not to be used as design criteria.

Coil Parameter

DC Coil Parameter								
Dash numbers	Rated voltage V		Coil resistance Ω ± 10%	Pick up voltage V(max) (75%of rated voltage)	Release voltage V(min) (10%of rated voltage)	Coil power W	Operate Time ms	Release Time ms
	Rated	Max						
003-900	3	3.9	10	2.25	0.3	0.9	<15	<10
005-900	5	6.5	28	3.75	0.5			
006-900	6	7.8	40	4.50	0.6			
009-900	9	11.7	90	6.75	0.9			
012-900	12	15.6	160	9.00	1.2			
015-900	15	19.5	250	10.25	1.5			
018-900	18	23.4	360	13.50	1.8			
024-900	24	31.2	640	18.00	2.4			
048-900	48	62.4	2560	36.00	4.8			
110-900	110	143	13445	82.50	11.0			
003-600	3	3.9	15	2.25	0.3	0.6	<15	<10
005-600	5	6.5	42	3.75	0.5			
006-600	6	7.8	60	4.50	0.6			
009-600	9	11.7	135	6.75	0.9			
012-600	12	15.6	240	9.00	1.2			
015-600	15	19.5	375	10.25	1.5			
018-600	18	23.4	540	13.50	1.8			
024-600	24	31.2	960	18.00	2.4			
048-600	48	62.4	3840	36.00	4.8			
110-600	110	143	20167	82.50	11.0			

CAUTION: 1.The use of any coil voltage less than the rated coil voltage will compromise the operation of the relay.
 2.Pickup and release voltage are for test purposes only and are not to be used as design criteria.

Operation condition

Insulation Resistance	1000MΩ min (at 500VDC)	Item 7 of IEC 60255-5
Dielectric Strength	Between contacts	50Hz 1500V
	Between contact and coil	50Hz 2500V 4000V (without Pin 6)
Shock resistance	200m/s ² 11ms	IEC 68-2-27 Test Ea
Vibration resistance	10Hz~55Hz double amplitude 1.5mm	IEC 68-2-6 Test Fc
Terminals strength	10N	IEC 68-2-21 Test Ua1
Solderability	235°C ± 2°C 3s ± 0.5s	IEC 68-2-20 Test Ta method 1
Ambient Temperature	-55°C ~ 100°C -55°C ~ 125°C	
Relative Humidity	85% (at 40°C)	IEC 68-2-3 Test Ca
Mass	27g (Open type) 30g	

Safety approvals

Safety approval	UL&CUR	TüV	CQC
Load	NO:40A/240VAC 30A/277VAC NC:30A/240VAC,30VDC 20A/277VAC Ballast:5A/280VAC TV-5 HP:NO:2 HP 250VAC A:1HP/16AFLA/120VAC 2HP/12AFLA/240VAC NC: 1½ HP 250VAC B:30LRA/10AFLA/120VAC 30LRA/10AFLA/240VAC	NO:40A/240VAC 14VDC 30A/277VAC NC:30A/240VAC 14VDC 20A/277VAC	NO:30A/240VAC NC:20A/240VAC

Dimensions

mm /inch

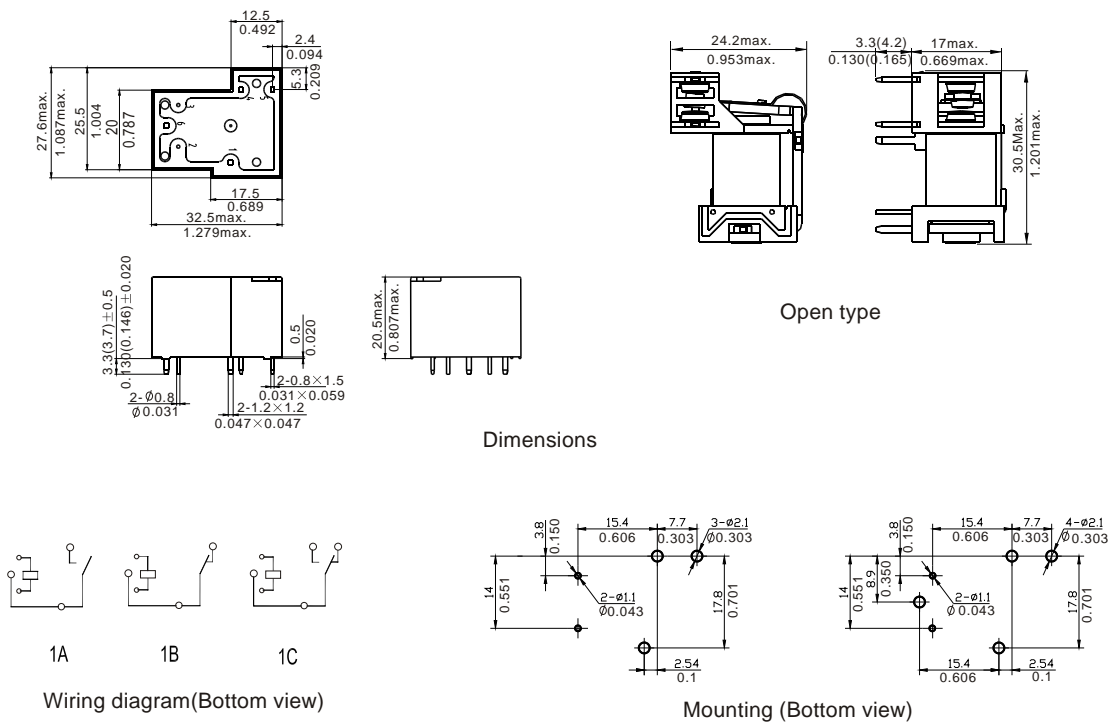

NOTES 1).Dimensions are in millimeters.
2).Inch equivalents are given for general information only.

Reference Data

