

MOC3031M, MOC3032M, MOC3033M, MOC3041M, MOC3042M, MOC3043M

6-Pin DIP Zero-Cross Optoisolators Triac Driver Output (250/400 Volt Peak)

Features

- Simplifies logic control of 115 VAC power
- Zero voltage crossing
- dv/dt of 2000 V/ μ s typical, 1000 V/ μ s guaranteed
- VDE recognized (File # 94766), ordering option V (e.g., MOC3043VM)

Applications

- | | |
|---------------------------|----------------------|
| ■ Solenoid/valve controls | ■ Lighting controls |
| ■ Static power switches | ■ AC motor drives |
| ■ Temperature controls | ■ E.M. contactors |
| ■ AC motor starters | ■ Solid state relays |

Description

The MOC303XM and MOC304XM devices consist of a AlGaAs infrared emitting diode optically coupled to a monolithic silicon detector performing the function of a zero voltage crossing bilateral triac driver.

They are designed for use with a triac in the interface of logic systems to equipment powered from 115 VAC lines, such as teletypewriters, CRTs, solid-state relays, industrial controls, printers, motors, solenoids and consumer appliances, etc.

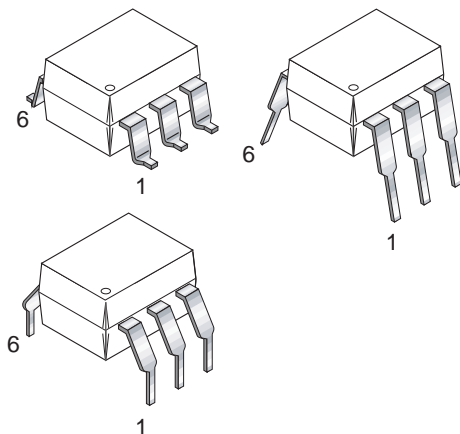

Schematic

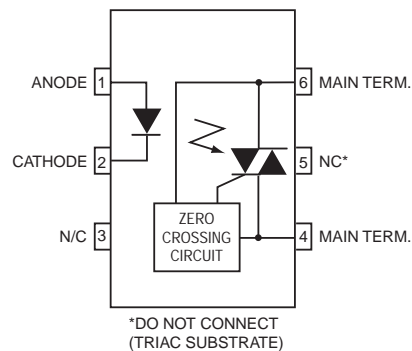

Absolute Maximum Ratings ($T_A = 25^\circ\text{C}$ unless otherwise noted)

Parameters	Symbol	Device	Value	Units
TOTAL DEVICE				
Storage Temperature	T_{STG}	All	-40 to +150	$^\circ\text{C}$
Operating Temperature	T_{OPR}	All	-40 to +85	$^\circ\text{C}$
Lead Solder Temperature	T_{SOL}	All	260 for 10 sec	$^\circ\text{C}$
Junction Temperature Range	T_J	All	-40 to +100	$^\circ\text{C}$
Isolation Surge Voltage ⁽¹⁾ (peak AC voltage, 60Hz, 1 sec duration)	V_{ISO}	All	7500	Vac(pk)
Total Device Power Dissipation @ 25 $^\circ\text{C}$ Derate above 25 $^\circ\text{C}$	P_D	All	250 2.94	mW mW/ $^\circ\text{C}$
EMITTER				
Continuous Forward Current	I_F	All	60	mA
Reverse Voltage	V_R	All	6	V
Total Power Dissipation 25 $^\circ\text{C}$ Ambient Derate above 25 $^\circ\text{C}$	P_D	All	120 1.41	mW mW/ $^\circ\text{C}$
DETECTOR				
Off-State Output Terminal Voltage	V_{DRM}	MOC3031M/2M/3M MOC3041M/2M/3M	250 400	V
Peak Repetitive Surge Current (PW = 100 μs , 120 pps)	I_{TSM}	All	1	A
Total Power Dissipation @ 25 $^\circ\text{C}$ Ambient Derate above 25 $^\circ\text{C}$	P_D	All All	150 1.76	mW mW/ $^\circ\text{C}$

Note

1. Isolation surge voltage, V_{ISO} , is an internal device dielectric breakdown rating. For this test, Pins 1 and 2 are common, and Pins 4, 5 and 6 are common.

Electrical Characteristics ($T_A = 25^\circ\text{C}$ Unless otherwise specified)**Individual Component Characteristics**

Parameters	Test Conditions	Symbol	Device	Min	Typ	Max	Units
EMITTER							
Input Forward Voltage	$I_F = 30\text{ mA}$	V_F	All		1.25	1.5	V
Reverse Leakage Current	$V_R = 6\text{ V}$	I_R	All		0.01	100	μA
DETECTOR							
Peak Blocking Current, Either Direction	Rated V_{DRM} , $I_F = 0$ (note 1)	I_{DRM1}	All			100	nA
Peak On-State Voltage, Either Direction	$I_{TM} = 100\text{ mA peak}$, $I_F = 0$	V_{TM}	All		1.8	3	V
Critical Rate of Rise of Off-State Voltage	$I_F = 0$ (Figure 9, note 3)	dv/dt	All	1000			V/ μs

Transfer Characteristics ($T_A = 25^\circ\text{C}$ Unless otherwise specified.)

DC Characteristics	Test Conditions	Symbol	Device	Min	Typ	Max	Units
LED Trigger Current	Main terminal voltage = 3V (note 2)	I_{FT}	MOC3031M/ MOC3041M MOC3032M/ MOC3042M MOC3033M/ MOC3043M			15 10 5	mA
Holding Current, Either Direction		I_H	All		400		μA

Zero Crossing Characteristics ($T_A = 25^\circ\text{C}$ Unless otherwise specified.)

Characteristics	Test Conditions	Symbol	Device	Min	Typ	Max	Units
Inhibit Voltage	$I_F = \text{rated } I_{FT}$, MT1-MT2 voltage above which device will not trigger off-state	V_{IH}	All			20	V
Leakage in Inhibited State	$I_F = \text{rated } I_F$, rated V_{DRM} , off-state	I_{DRM2}	All			500	μA

Note

1. Test voltage must be applied within dv/dt rating.
2. All devices are guaranteed to trigger at an I_F value less than or equal to max I_{FT} . Therefore, recommended operating I_F lies between max I_{FT} (15 mA for MOC3031M & MOC3041M, 10 mA for MOC3032M & MOC3042M, 5 mA for MOC3033M & MOC3043M) and absolute max I_F (60 mA).
3. This is static dv/dt. See Figure 9 for test circuit. Commutating dv/dt is a function of the load-driving thyristor(s) only.

Figure 1. LED Forward Voltage vs. Forward Current

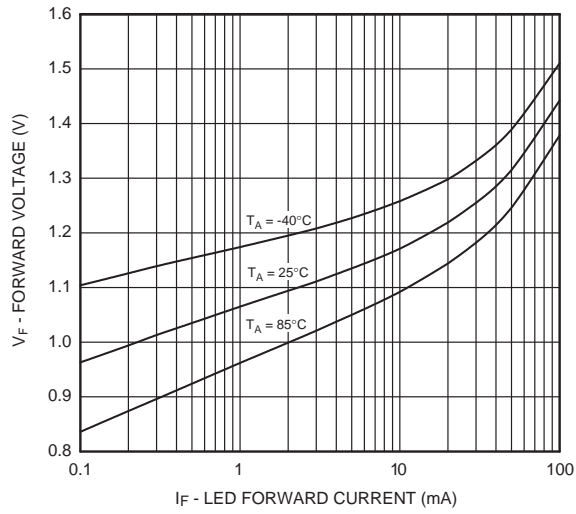

Figure 2. On-State Characteristics

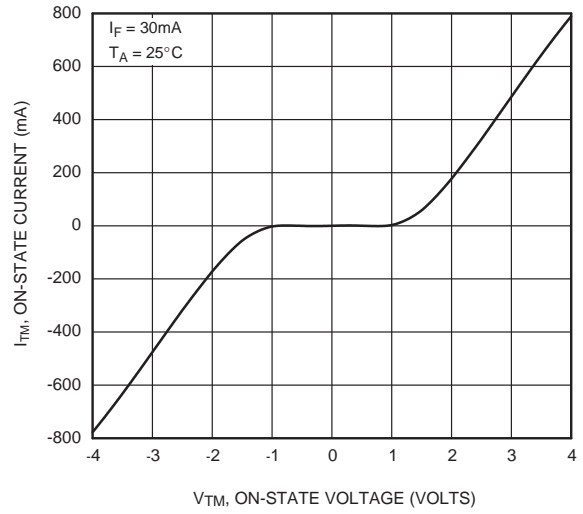

Figure 3. Trigger Current vs. Temperature

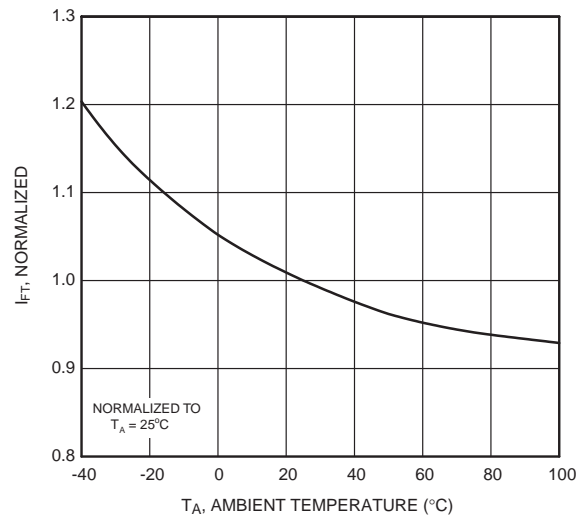

Figure 4. Leakage Current, I_{DRM} vs. Temperature

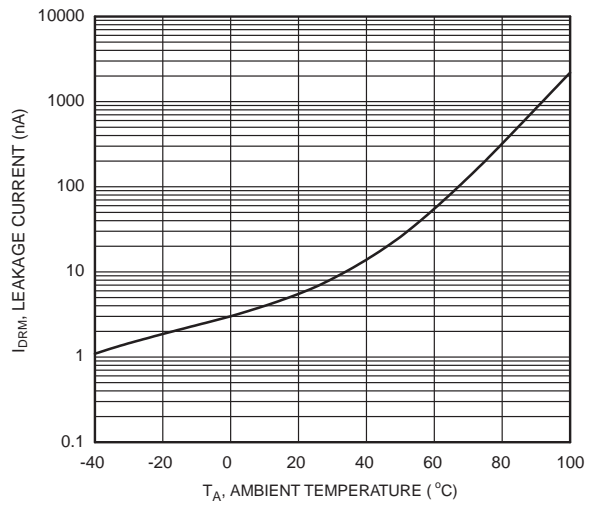

Figure 5. I_{DRM2} - Leakage in Inhibit State vs. Temperature

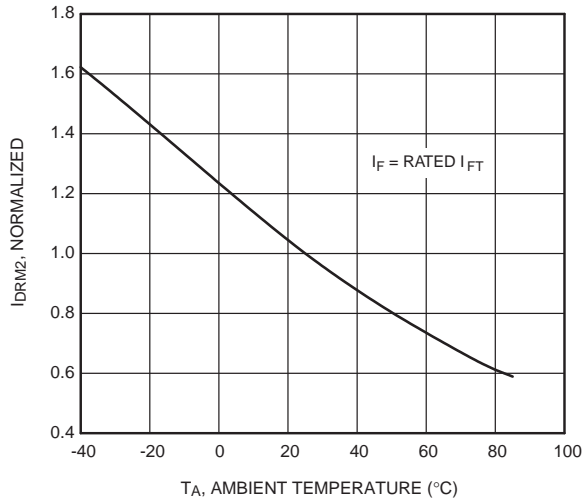

Figure 6. LED Current Required to Trigger vs. LED Pulse Width

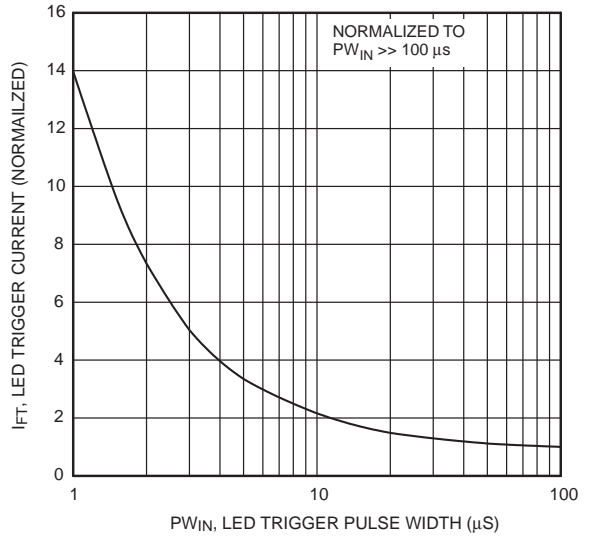

Figure 7. Holding Current, I_H vs. Temperature

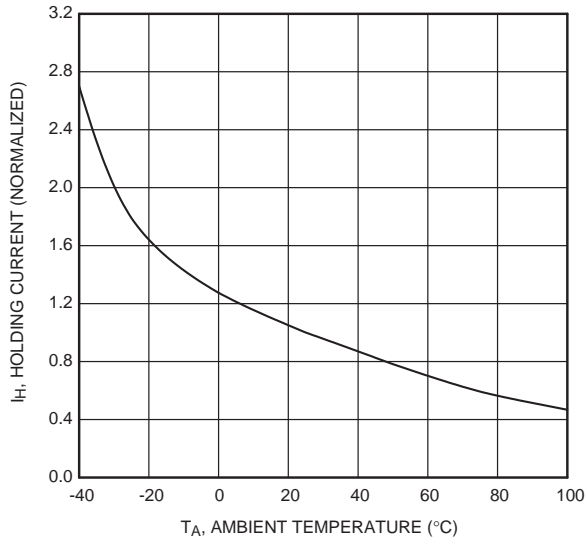
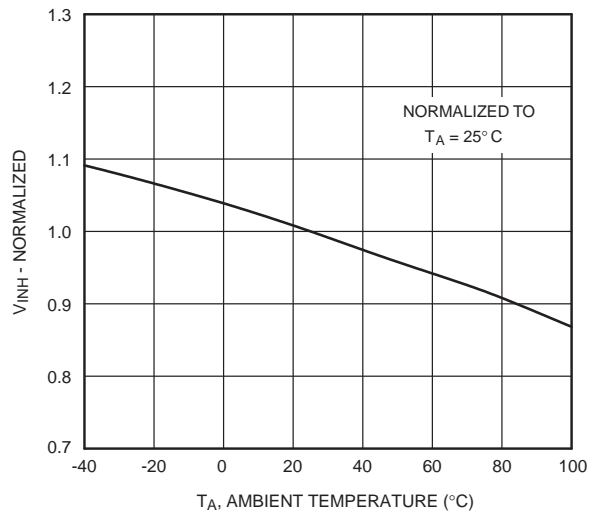

Figure 8. Inhibit Voltage vs. Temperature



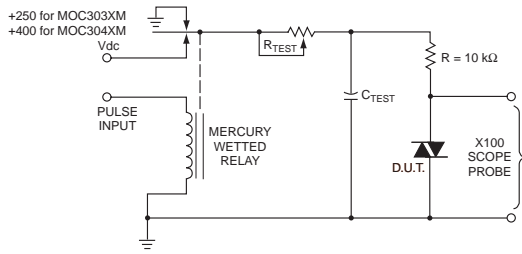

Figure 9. Static dv/dt Test Circuit

1. The mercury wetted relay provides a high speed repeated pulse to the D.U.T.
2. 100x scope probes are used, to allow high speeds and voltages.
3. The worst-case condition for static dv/dt is established by triggering the D.U.T. with a normal LED input current, then removing the current. The variable R_{TEST} allows the dv/dt to be gradually increased until the D.U.T. continues to trigger in response to the applied voltage pulse, even after the LED current has been removed. The dv/dt is then decreased until the D.U.T. stops triggering. τ_{RC} is measured at this point and recorded.

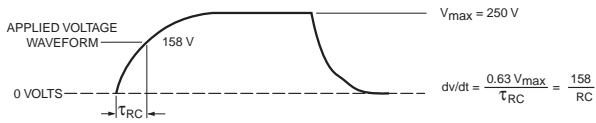

Figure 10. Static dv/dt Test Waveform (MOC3031M, MOC3032M, MOC3033M)

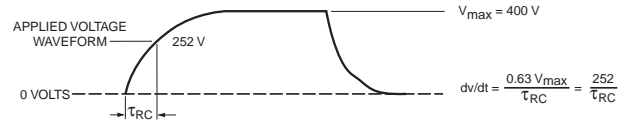
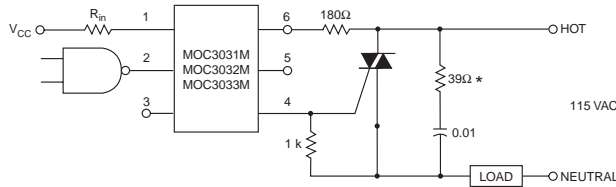

Figure 11. Static dv/dt Test Waveform (MOC3041M, MOC3042M, MOC3043M)

Typical circuit (Fig 12, 13) for use when hot line switching is required. In this circuit the “hot” side of the line is switched and the load connected to the cold or neutral side. The load may be connected to either the neutral or hot line.

R_{in} is calculated so that I_F is equal to the rated I_{FT} of the part, 5 mA for the MOC3033M and MOC3043M, 10 mA for the MOC3032M and MOC3042M, or 15 mA for the MOC3031M and MOC3041M. The 39 ohm resistor and 0.01 μ F capacitor are for snubbing of the triac and may or may not be necessary depending upon the particular triac and load used.



*For highly inductive loads (power factor < 0.5), change this value to 360 ohms.

Figure 12. Hot-Line Switching Application Circuit (MOC3031M, MOC3032M, MOC3033M)

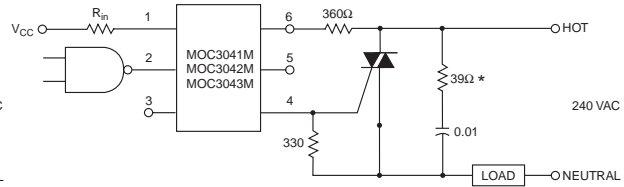

*For highly inductive loads (power factor < 0.5), change this value to 360 ohms.

Figure 13. Hot-Line Switching Application Circuit (MOC3041M, MOC3042M, MOC3043M)

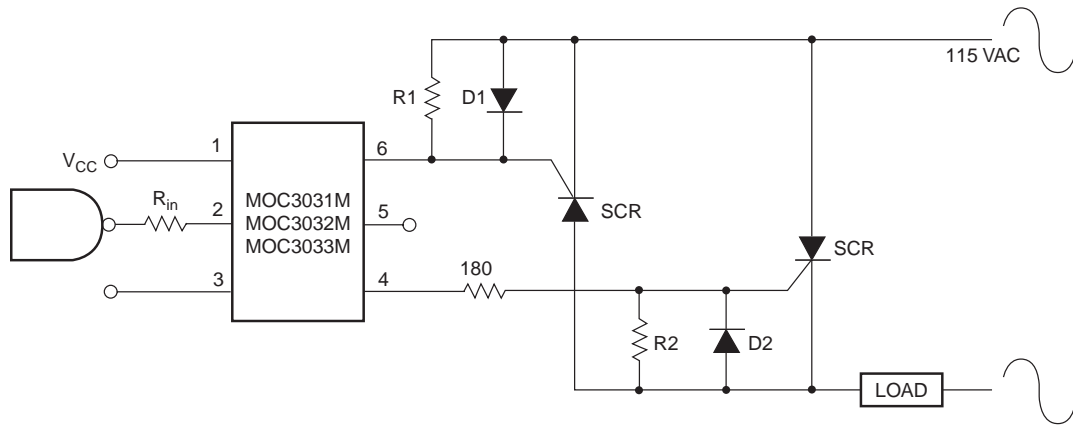

**Figure 14. Inverse-Parallel SCR Driver Circuit
(MOC3031M, MOC3032M, MOC3033M)**

Suggested method of firing two, back-to-back SCR's with a Fairchild triac driver. Diodes can be 1N4001; resistors, R1 and R2, are optional 1 k ohm.

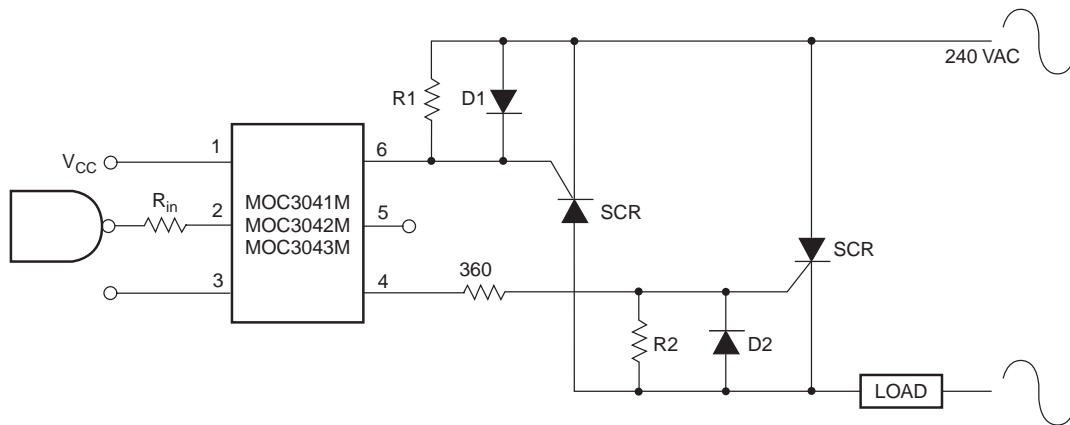
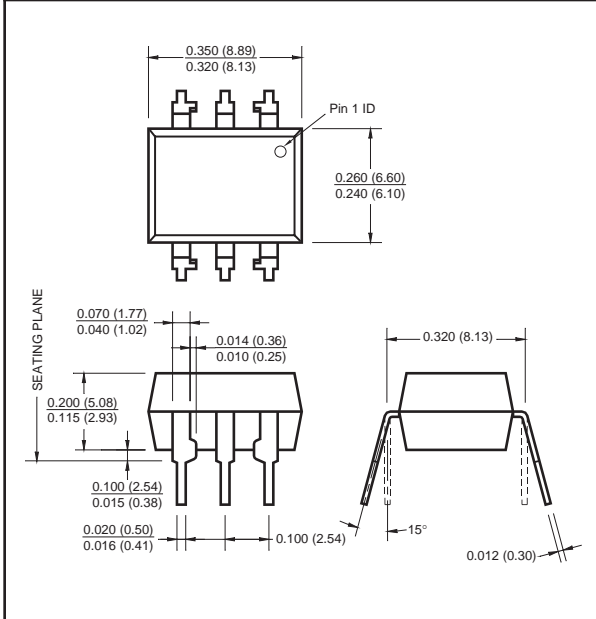

**Figure 15. Inverse-Parallel SCR Driver Circuit
(MOC3041M, MOC3042M, MOC3043M)**

Suggested method of firing two, back-to-back SCR's with a Fairchild triac driver. Diodes can be 1N4001; resistors, R1 and R2, are optional 330 ohm.

Note: This optoisolator should not be used to drive a load directly. It is intended to be a trigger device only.

Package Dimensions (Through Hole)



Package Dimensions (Surface Mount)

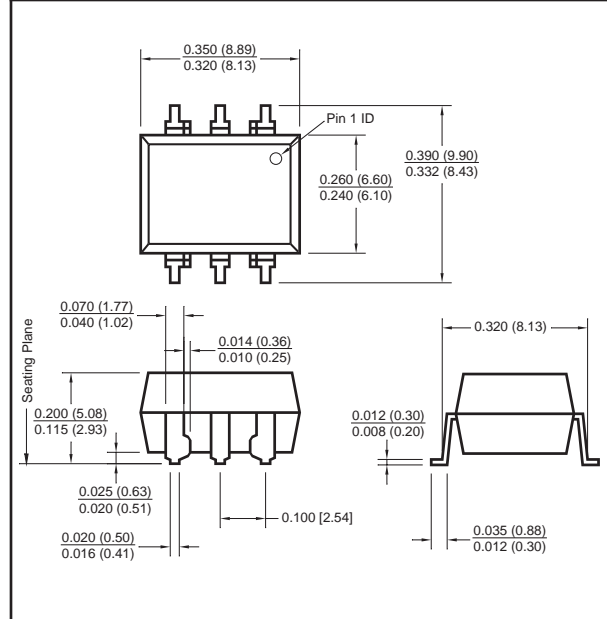

Package Dimensions (0.4" Lead Spacing)

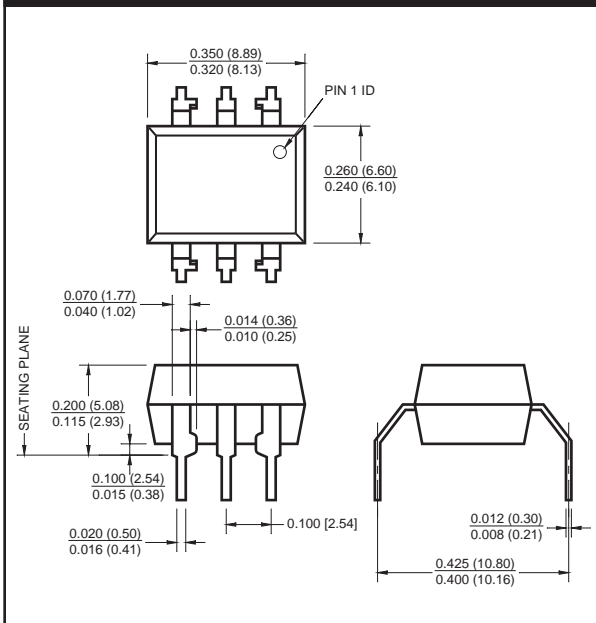

Recommended Pad Layout for Surface Mount Leadform

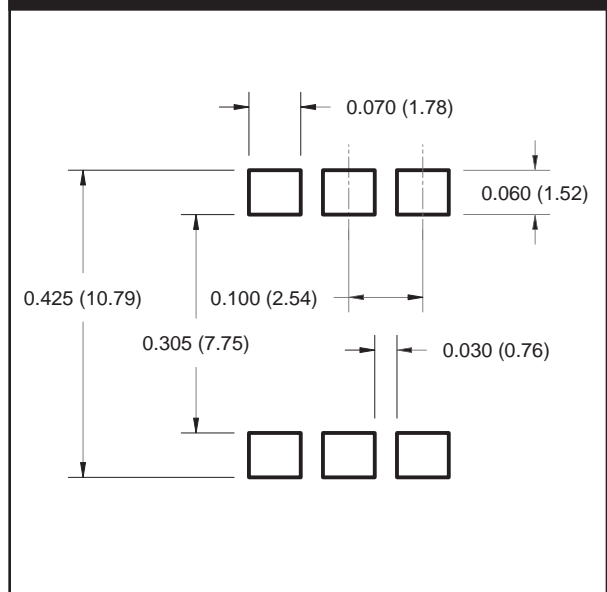

NOTE

All dimensions are in inches (millimeters)

Ordering Information

Option	Order Entry Identifier	Description
S	S	Surface Mount Lead Bend
SR2	SR2	Surface Mount; Tape and reel
T	T	0.4" Lead Spacing
V	V	VDE 0884
TV	TV	VDE 0884, 0.4" Lead Spacing
SV	SV	VDE 0884, Surface Mount
SR2V	SR2V	VDE 0884, Surface Mount, Tape & Reel

Carrier Tape Specifications (White Package, -M Suffix)

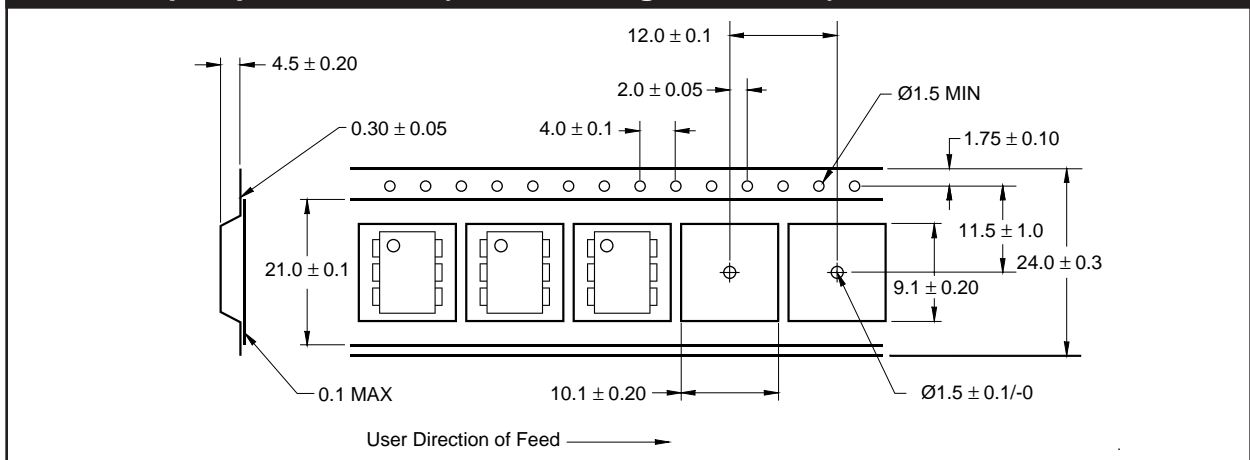

NOTE

All dimensions are in inches (millimeters)

Marking Information

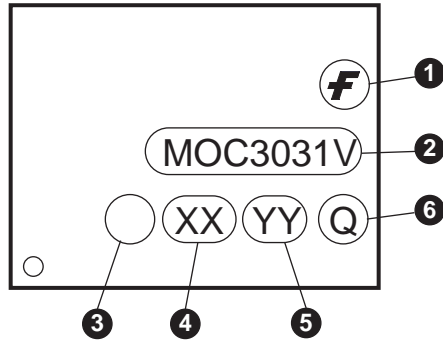

Definitions

1	Fairchild logo
2	Device number
3	VDE mark (Note: Only appears on parts ordered with VDE option – See order entry table)
4	One digit year code, e.g., '3'
5	Two digit work week ranging from '01' to '53'
6	Assembly package code

*Note – Parts that do not have the 'V' option (see definition 3 above) that are marked with date code '325' or earlier are marked in portrait format.

Reflow Profile (White Package, -M Suffix)

