

# DM13G

---

*Version* : A.002  
*Issue Date* : 2008/11/10  
*File Name* : SP-DM13G-A.002.doc  
*Total Pages* : 26

***16-bit Constant Current LED Driver  
With Error Detection***



## DM13G

### 16-bit Constant Current LED Driver With Error Detection

#### General Description

DM13G is a constant-current sink driver specifically designed for LED display applications. The device incorporates shift registers, data latches, and constant current circuitry on the silicon CMOS chip. The maximum output current value of all 16 channels is adjustable by a single external resistor. The global current also can be further adjusted by 7-bit serial shift-in data. Its built-in LED open/short detection, output channels short to GND detection and thermal alarm circuits help users detect LED failures, outputs short and overheating. There are two methods to communicate the error messages to the system. One is through serial output data to indicate which channel has failure. The other is by means of dedicated Alarm pin.

#### Features

- Constant-current outputs: 5mA to 90mA adjustable by one external resistor
- Maximum output voltage: 17V
- Maximum clock frequency: 30MHz
- 7-bit linear global brightness control
- Built-in LED open/short detection: Real-time detection or Smart detection
- Outputs short to GND detection: Smart detection
- Fast detecting response: 100ns (min.)
- Over temperature protection: Alarm (junction temperature > 130°C)  
Shutdown (junction temperature > 170°C)
- Sleep mode selection :sleep current < 5uA (typ.)
- Ghost image elimination
- In-rush current control
- Schmitt trigger input
- Power supply voltage: 3.0V to 5.5V

#### Applications

- LED Variable Message Signs (VMS) System
- Indoor/Outdoor LED Video Display

#### Package

- SSOP28, TSSOP28E, QFN32

**Block Diagram**

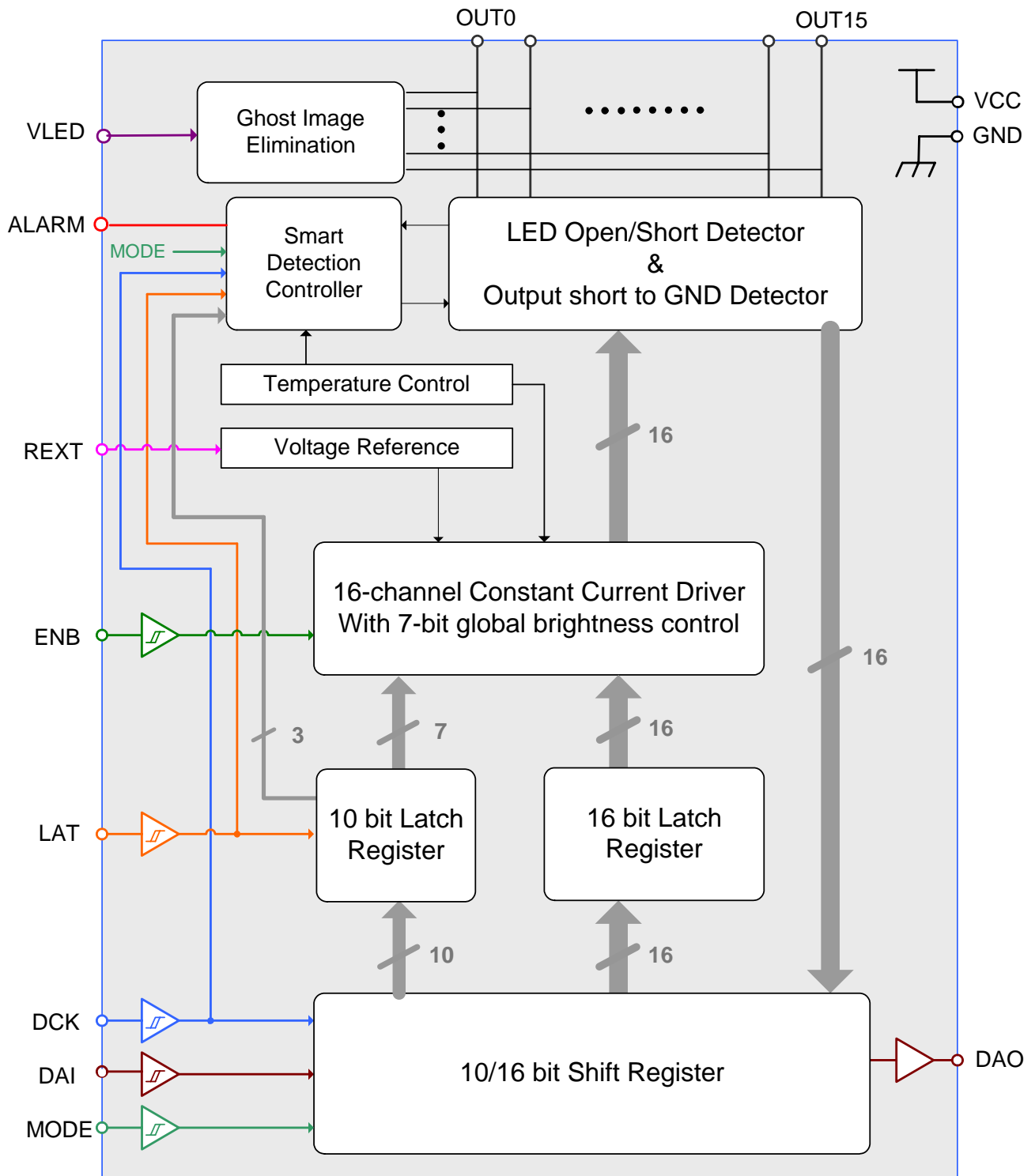

## Pin Connection

### SSOP28

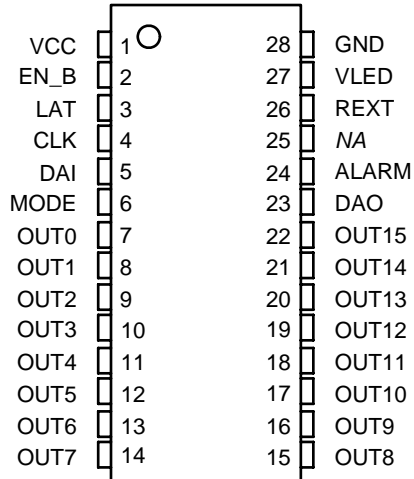

### TSSOP28E

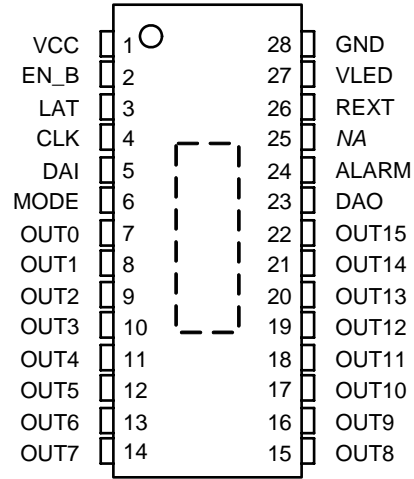

### QFN32

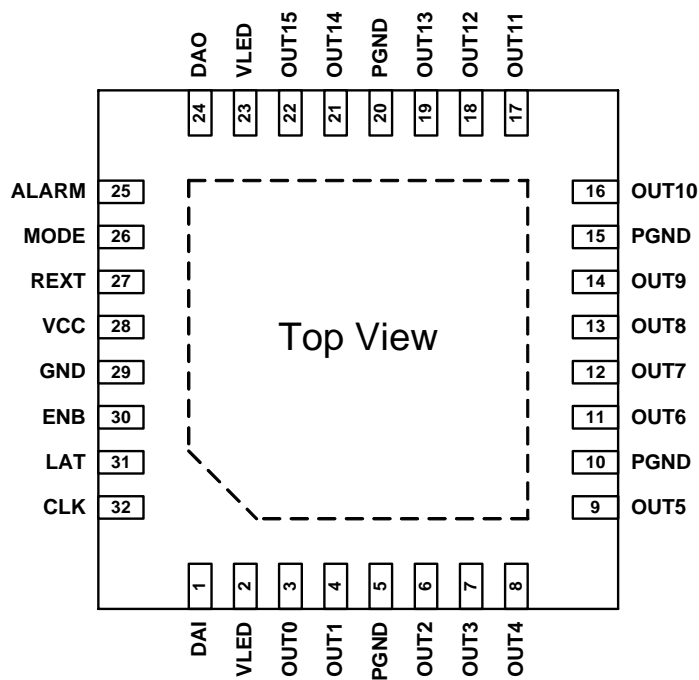

## Pin Description

PIN No.	PIN NAME	FUNCTION
SSOP28/TSSOP28: 1 QFN32: 28	VCC	Supply voltage terminal.
SSOP28/TSSOP28: 2 QFN32: 30	ENB	Output enable terminal: 'H' for all outputs are turned off , 'L' for all outputs are active.
SSOP28/TSSOP28: 3 QFN32: 31	LAT	Input terminal of data strobe. Data on shift register goes through at the rising edge of LAT (edge trigger). Otherwise, data is latched.
SSOP28/TSSOP28: 4 QFN32: 32	CLK	Synchronous clock input terminal for serial data transfer. Data is sampled at the rising edge of CLK.
SSOP28/TSSOP28: 5 QFN32: 1	DAI	Serial data input terminal.
SSOP28/TSSOP28: 6 QFN32: 26	MODE	Serial data input selection: 'L' for output channel on/off data (SD Mode), 'H' for 7-bit global brightness data and 3-bit error function selection (CD Mode)
SSOP28/TSSOP28: 7~22 QFN32: 3~4,6~9, 11~14,16~19,21~22	OUT0~15	Sink constant-current outputs (open-drain).
SSOP28/TSSOP28: 23 QFN32: 24	DAO	Serial data output terminal.
SSOP28/TSSOP28: 24 QFN32: 25	ALARM	Output open drain terminal: (connected to a pull-high resistor) 'H' for normal conditions, 'L' for LED open/short, outputs short to GND or chip overheated.
SSOP28/TSSOP28: 25	NA	Not used
SSOP28/TSSOP28: 26 QFN32: 27	REXT	External resistors connected between REXT and GND for output current value setting.
SSOP28/TSSOP28: 27 QFN32: 2,23	VLED	Connect to VLED to eliminate ghost image.
SSOP28/TSSOP28: 28 Thermal pad QFN32: 5,10,15,20,29 Thermal pad	GND	Ground terminal.

## Equivalent Circuit of Inputs and Outputs

- 1. CLK, DAI, LAT, ENB, MODE terminals ( Schmitt Trigger Input )

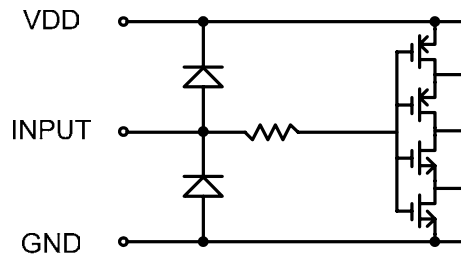

- 2. DAO terminals

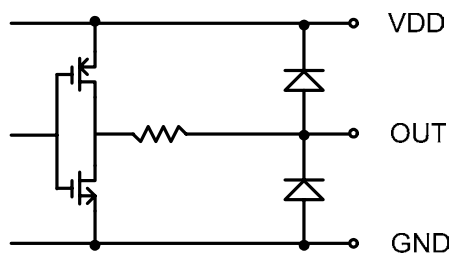

- 3. ALARM terminal

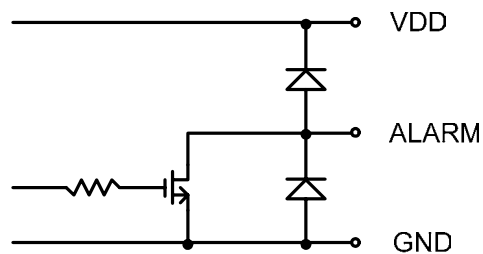

## Maximum Ratings (Ta=25°C, Tj(max) = 150°C)

CHARACTERISTIC	SYMBOL	RATING	UNIT
Supply Voltage	VCC	-0.3 ~ 7.0	V
Input Voltage	VIN	-0.3 ~ VCC+0.3	V
Output Current	IOUT	90	mA
Output Voltage	VOUT	-0.3 ~ 17	V
Input Clock Frequency	FCKI	30	MHz
GND Terminal Current	IGND	1500	mA
Power Dissipation	PD	1.56 ( SSOP28 : Ta=25°C )	W
		5.00 ( TSSOP28E : Ta=25°C )	
		3.46 ( QFN32 : Ta=25°C )	
Thermal Resistance <sup>1</sup>	Rth(j-a)	80.0 ( SSOP28 )	°C/W
		25.0 ( TSSOP28E )	
		36.1 ( QFN32 )	
Operating Temperature	Top	-40 ~ 85	°C
Storage Temperature	Tstg	-55 ~ 150	°C

## Recommended Operating Condition

CHARACTERISTIC	SYMBOL	CONDITION	MIN.	TYP.	MAX.	UNIT
Supply Voltage	VCC	—	3.0	—	5.5	V
Output Voltage	VOUT	Driver On <sup>2</sup>	—	—	2/3VCC	V
Output Voltage	VOUT	Driver Off <sup>3</sup>	—	—	17	
Output Current	IO	OUTn	5	—	90	mA
	IOH	VOH = VCC – 0.2 V	—	—	+1.2	
	IOL	VOL = 0.2 V	—	—	-1.4	
Input Voltage	VIH	VCC = 3.3 V ~ 5V	0.7VCC	—	VCC	V
	VIL		0.0	—	0.3VCC	
Input Clock Frequency	FCKI	Cascade Operation	—	—	30	MHz
LAT Pulse Width	tw LAT	VCC = 5.0V	—	15	—	ns
CLK Pulse Width	tw CLK		—	13	—	
ENB Pulse Width	tw ENB		50	—	—	
Set-up Time for DAI	tsetup(D)		—	10	—	
Hold Time for DAI	thold(D)		—	10	—	
Set-up Time for LAT	tsetup(L)		—	10	—	
Hold Time for LAT	thold(L)		—	10	—	
Open/Short Detection Response	tdet		—	100	—	

<sup>1</sup> Mounted on 4-layer board (No airflow).

<sup>2</sup> Notice that if VOUT is higher than 2/3VCC, it will be called as LED short error.

<sup>3</sup> The driver output voltage including any overshoot stress has to be compliant with the maximum voltage (17V).

## Electrical Characteristics (VCC = 5.0 V, Ta = 25°C unless otherwise noted)

CHARACTERISTIC	SYMBOL	CONDITION	MIN.	TYP.	MAX.	UNIT
Input Voltage "H" Level	VIH	CMOS logic level	0.7VCC	—	VCC	V
Input Voltage "L" Level	VIL	CMOS logic level	GND	—	0.3VCC	
Output Leakage Current	IOL	VOH = 17 V	—	—	±0.1	uA
Output Voltage (S-OUT)	VOL	IOL = 1.4 mA	—	—	0.2	V
	VOH	IOH = 1.2 mA	VCC-0.2	—	—	
Output Current Skew (Channel-to-Channel) *1	IOL1	VOUT = 1.0 V Rrest = 3.9 KΩ	—	±1	±3	%
Output Current Skew (Chip-to-Chip) *2	IOL2		—	±3	±6	%
Output Voltage Regulation	% / VOUT	Rrest = 3.9 KΩ VOUT = 1 V ~ 3 V	—	±0.1	±0.5	% / V
Supply Voltage Regulation	% / VCC	Rrest = 3.9 KΩ	—	±1	±4	
Differential Linearity	DLE	Rrest = 3.9 KΩ	—	—	±1	LSB
LED Open Detection Threshold	V(od)	all outputs turn on	—	0.2	—	V
LED Short Detection Threshold	V(sd)		—	2/3VCC	—	
Thermal Alarm Threshold	T(alm)	junction temperature	—	130	—	°C
Thermal Shutdown Threshold	T(sht)		—	170	—	
Supply Current	IDD(off)	power on all pins are open unless VCC and GND	—	1.2	—	mA
	IDD(off)	input signal is static Rrest = 3.9 KΩ all outputs turn off	—	6.4	—	
	IDD(on)	input signal is static Rrest = 3.9 KΩ all outputs turn on	—	7.1	—	
	IDD(off)	input signal is static Rrest = 900 Ω all outputs turn off	—	24.7	—	
	IDD(on)	input signal is static Rrest = 900 Ω all outputs turn on	—	25.3	—	
	IDD(sleep)	Sleep current (steady state)	—	5	200	uA

\*1 Channel-to-channel skew is defined as the ratio between (any Iout – average Iout) and average Iout, where average Iout = (Imax + Imin) / 2.

\*2 Chip-to-Chip skew is defined as the range into which any output current of any IC falls.

**Switching Characteristics** ( $V_{CC} = 5.0V$ ,  $T_a = 25^\circ C$  unless otherwise noted)

CHARACTERISTIC		SYMBOL	CONDITION	MIN.	TYP.	MAX.	UNIT
Propagation Delay (‘L to ‘H’)	ENB-to-OUT0	tpLH	$V_{IH} = V_{CC}$ $V_{IL} = GND$ $R_{rxt} = 3.9\ K\Omega$ $V_L = 5.0\ V$ $R_L = 0.18\ K\Omega$ $C_L = 13\ pF$ $R_a = 500\ \Omega$	—	26	—	ns
	LAT-to-OUT0			—	31	—	
	CLK-to-DAO			—	19	—	
Propagation Delay (‘H’ to ‘L’)	ENB-to-OUT0	tpHL		—	31	—	
	LAT-to-OUT0			—	32	—	
	CLK-to-DAO			—	20	—	
Output Current Rise Time		tor	—	10	—		
Output Current Fall Time		tof	—	10	—		
Output Delay Time ( $OUT_{(n)}$ -to- $OUT_{(n+1)}$ )		tod	—	3	—		

**Switching Characteristics** ( $V_{CC} = 3.3V$ ,  $T_a = 25^\circ C$  unless otherwise noted)

CHARACTERISTIC		SYMBOL	CONDITION	MIN.	TYP.	MAX.	UNIT
Propagation Delay (‘L to ‘H’)	ENB-to-OUT0	tpLH	$V_{IH} = V_{CC}$ $V_{IL} = GND$ $R_{rxt} = 3.9\ K\Omega$ $V_L = 5\ V$ $R_L = 0.18\ K\Omega$ $C_L = 13\ pF$ $R_a = 500\ \Omega$	—	36	—	ns
	LAT-to-OUT0			—	37	—	
	CLK-to-DAO			—	22	—	
Propagation Delay (‘H’ to ‘L’)	ENB-to-OUT0	tpHL		—	35	—	
	LAT-to-OUT0			—	37	—	
	CLK-to-DAO			—	23	—	
Output Current Rise Time		tor	—	14	—		
Output Current Fall Time		tof	—	14	—		
Output Delay Time ( $OUT_{(n)}$ -to- $OUT_{(n+1)}$ )		tod	—	3	—		

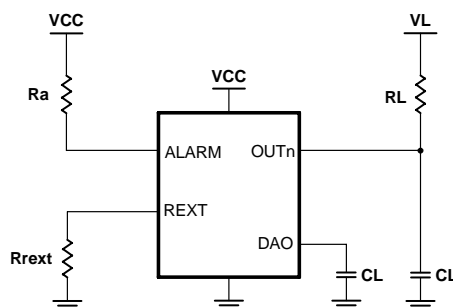

Switching Characteristics Test Circuit

## Timing Diagram

### 1. CLK-DAI, DAO

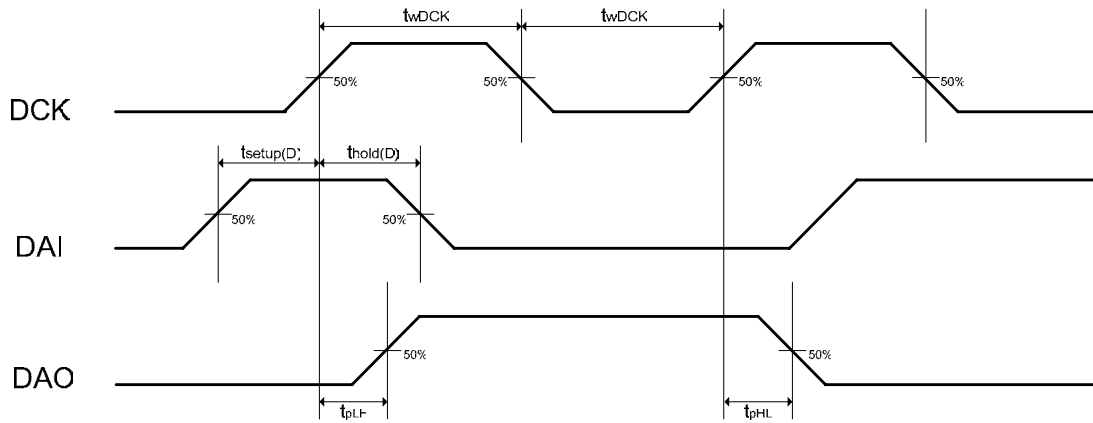

### 2. CLK-LAT

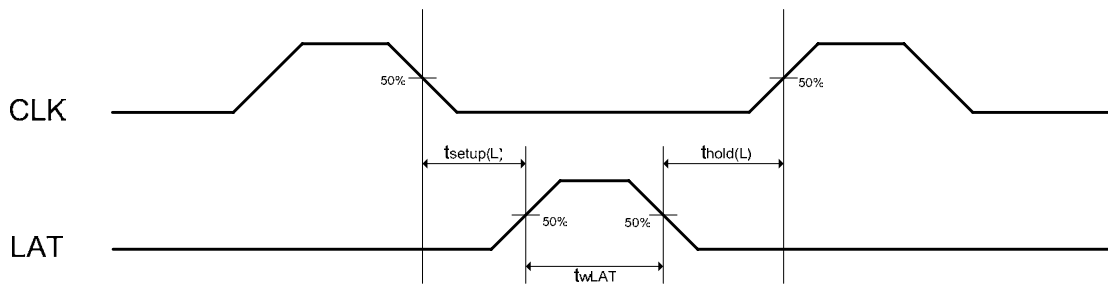

### 3. LAT-OUT0

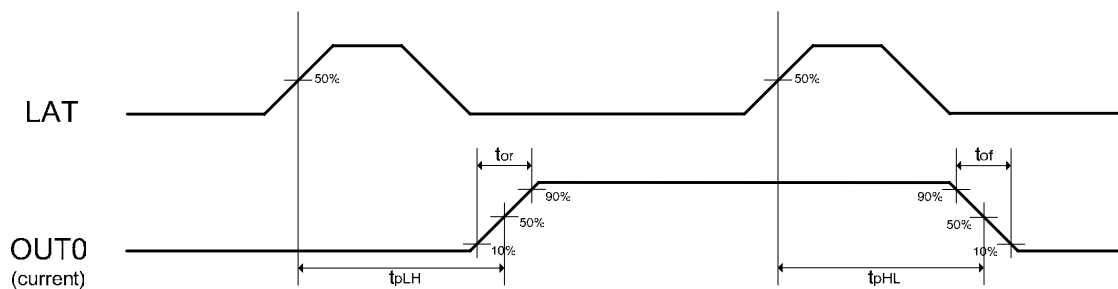

## Timing Diagram

### 4. ENB-OUT0

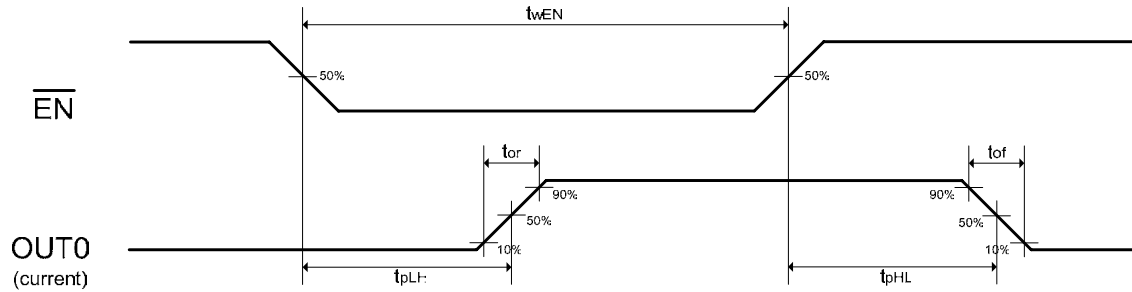

### 5. $OUT_{n+1}$ - $OUT_n$

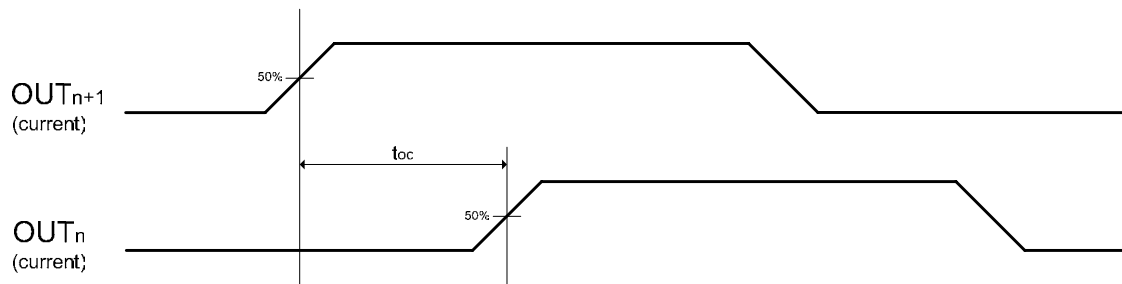

## Constant-Current Output

Constant-current value of each output channel is set by an external resistor connected between the REXT pin and GND. Varying the resistor value can adjust the current scale ranging from 5mA to 90mA. The reference voltage of REXT terminal (V<sub>rext</sub>) is approximately 1.23V. The output current value is calculated roughly by the following equation:

$$I_{max} \cong \frac{V_{rext} (V)}{R_{rext} (\Omega)} \times 64$$

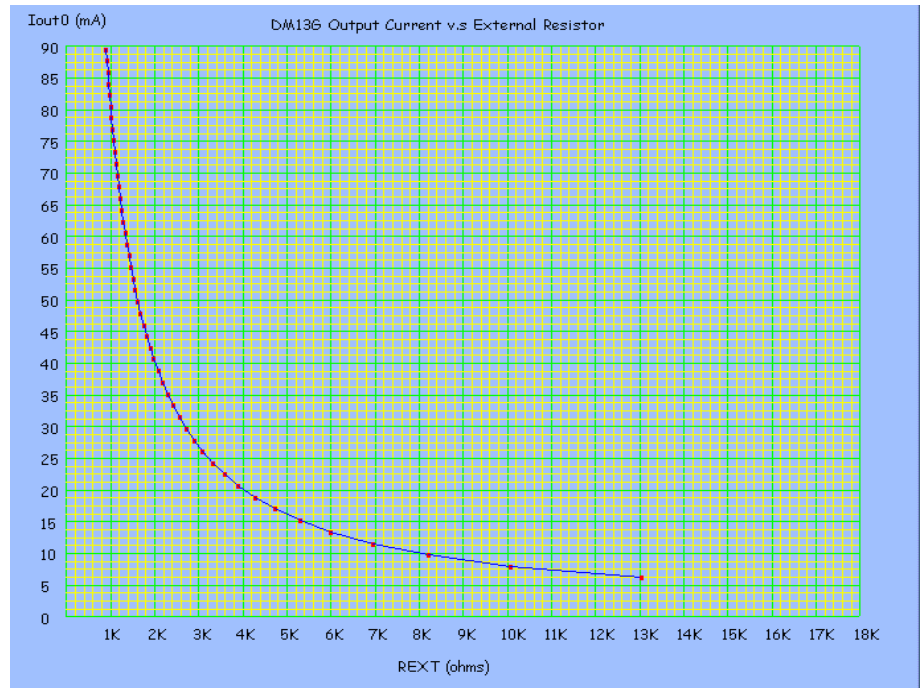

In order to obtain a good performance of constant-current output, a suitable output voltage is necessary. Users can get related information about the minimum output voltage below.

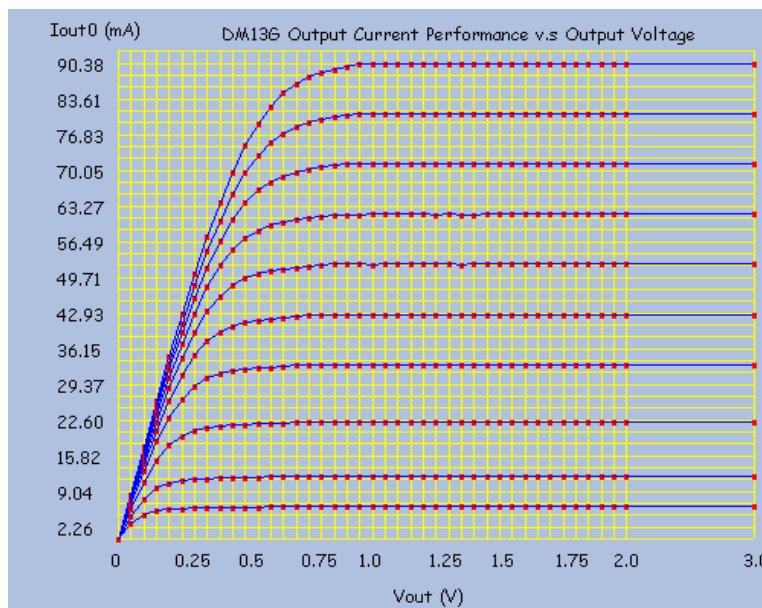

## Serial Data Interface

When MODE pin is set to low, the serial-in data (DAI) will be clocked into 16 bit shift register synchronized on the rising edge of the clock (CLK). The data '1' represents the corresponding current output 'ON', while the data '0' stands for 'OFF'. The data will be transferred into the 16 bit latch synchronized at the rising edge of the strobe signal (LAT); otherwise, the data will be latched. The latch pulse should be sent after the falling edge of the last clock within a frame data. The trigger timing of the serial-out data (DAO) will be shifted out on synchronization to the rising edge of the clock. All outputs are turned off while ENB is kept at high level. And they are active when ENB shift to low.

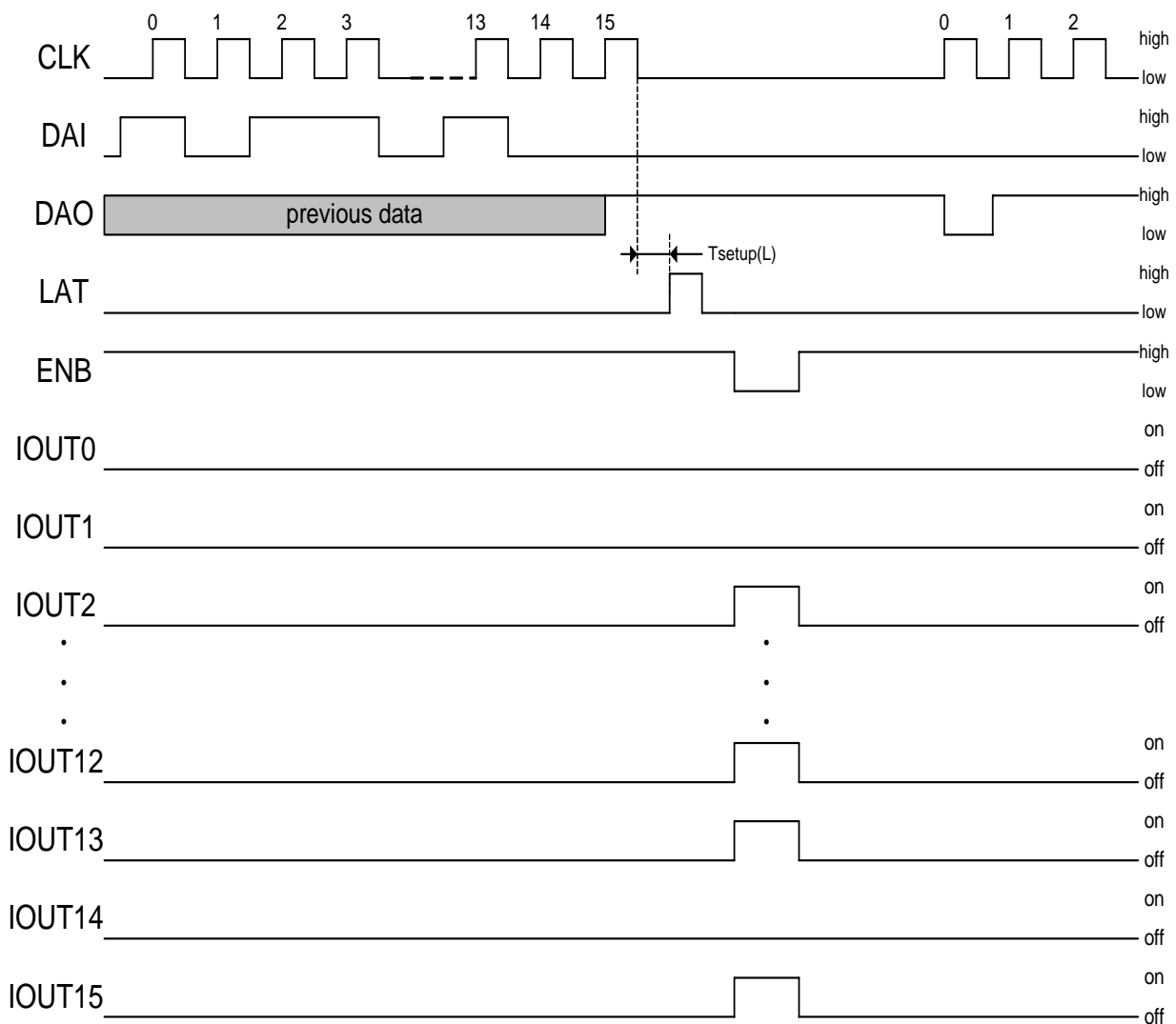

## Operation Mode

DM13G has two operating modes depending on the signal MODE. Table 1 shows the available operating modes. When MODE = H, the device operates at the CD mode. CD mode is used to set 7-bit global brightness control data and 3-bit error detection type data. When MODE = L, the device becomes SD mode. SD mode is used to serial-in image data.

Table 1. Two Operating Modes

MODE	OPERATION MODE	SHIFT REGISTER
L	Serial-in Data Input Mode (SD mode)	16-bit
H	Command Data Input Mode (CD mode)	10-bit

## SD Mode Data Format

MSB										LSB
15	14	13	12	11	...	4	3	2	1	0
OUT15	OUT14	OUT13	OUT12	OUT11	...	OUT4	OUT3	OUT2	OUT1	OUT0
Shift-in first										

SD MODE: MODE = 'L' (16-bit shift register)

## CD Mode Data Format

MSB							LSB		
9	8	7	6	5	4	3	2	1	0
G[6]	G[5]	G[4]	G[3]	G[2]	G[1]	G[0]	ER[2]	ER[1]	ER[0]
Shift-in first									

G[6:0] : Global Brightness Control Data      ER[2:0] : Function Selection

CD MODE: MODE = 'H' (10-bit shift register)

### a. Global Brightness Control

In the monochrome or full color LED display applications, for obtaining the uniformity, the white balance between modules or ICs, or the accommodation to ambient light, DM13G offers a convenient way by fine tuning the whole output current at the same time. To further adjust the current level linearly, the system shall set the MODE pin to high and then shift in 7 bit data code through DAI pin. The MSB should be shifted-in first. Take the input code G[6:0]= (MSB)1001011(LSB) for example. The new current is then equal to the base current multiplied by the ratio  $(2^6 + 2^3 + 2^1 + 2^0 + 1) / 128$ . The 7 bit data won't be changed until

the next new data is latched. Note that the default code 1000000 exists in chip memory when power on, so the output current is equal to the half of base current.

## b. Function Selection

DM13G provide several functions, like table 2 shows. The default function after power on is Real-Time LED Open Detection (ER[2:0]=111).

Table 2. Function Table

ER[2:0]	Functions
000	Normal
001	Smart Outputs Short to GND Detection
010	Smart LED Short Detection
011	Smart LED Open Detection
101	Sleep
110	Real-Time LED Short Detection
111	Real-Time LED Open Detection

### b.1 LED Open/Short Detection (Real-Time or Smart Detection)

Test result for open/short detection of DM13G could be retrieved from ALARM pin or serial-out (DAO) data. Set the ER[2:0] = 111 or 011 to activate OPEN detection, it will be identified as a LED open failure when there is a current passing through the output but the voltage is below 0.2V. Set the ER[2:0] =110 or 010 to activate SHORT detection, it will be identified as a LED short failure when there is a current passing through the output but the voltage is above 2/3 VCC.

When DM13G operates at real-time LED open/short detection type (ER[2:0]=111/110), after a LAT pulse at MODE='L', with the following conditions: the shift register corresponding to particular output channel saves an image data of '1', the output enable terminal is activated (ENB='L'); DM13G will execute LED open/short detection then save the result within the particular shift register. By using the error message sent by serial-out, the controller can identify the status of every LED driven by each channel. For either open or short detection, the input image data of the channel is '1' and the serial-out data is '0' then a LED works normally, but if the serial-out data is '1' then a LED failure has occurred. If the input of image data is '0' or the output enable terminal is inactive (ENB='H'), it will not execute any detection for the particular channel, and the serial-out data will always be '0'.



The response for LED open/short detection of DM13G is very fast (min. 100ns). And it provides multi solutions like *alarm*, *real-time monitor* and *smart detection* to be selected. All of these are “invisible failure detection”. Accordingly, it is more flexible and well adapted to the system requirements.

## b.2 Outputs Short to GND Detection

Outputs short to GND detection of DM13G could be retrieved from ALARM pin or serial-out (DAO) data. Set the ER[2:0] = 001 to activate output short detection, it will be identified as a output short failure when the output turn off but the voltage is below 0.2V.

When the MODE signal transfers from ‘H’ to ‘L’, the outputs short to GND detection will start after the first LAT pulse at MODE = ‘L’, the device will force all outputs turn off automatically, and start to detect output short error until the next falling edge of the CLK pulse. After the falling edge of CLK, the output current will return to normal value. When an output short detection finished, the device will return to default detection type (real-time LED open detection type). If there is any ‘1’ received from serial-out, it can pinpoint which channel is failed.

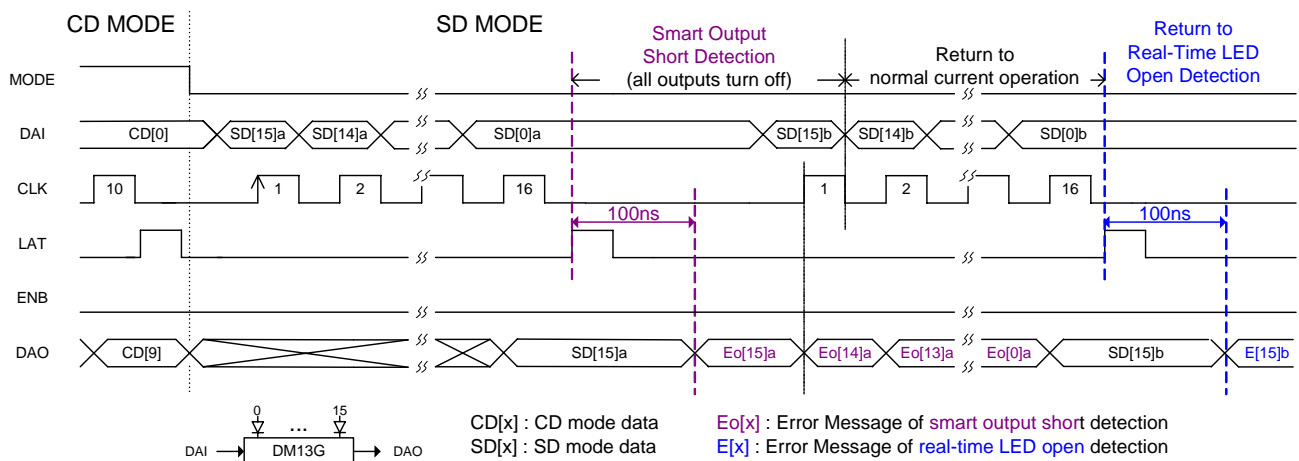

## b.3 Normal

When DM13G operates at normal type (ER[2:0]=000), the DM13G will do real-time LED open detection, but the DAO pin will just send out the original serial-in data not the error message. Although the DAO pin will not send out the error message, but users can judge the LED open error by ALARM pin.

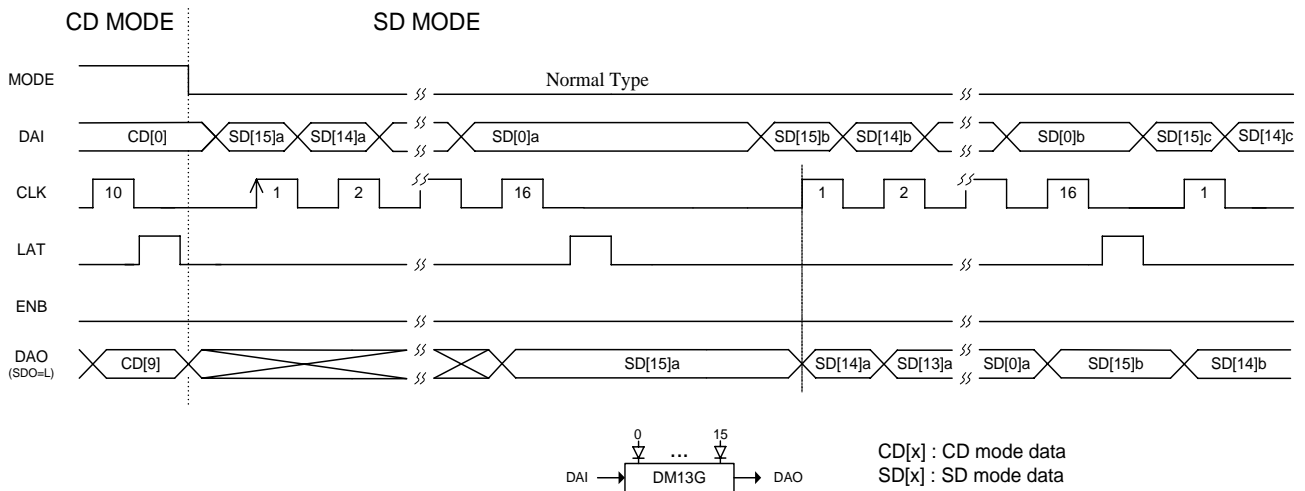

### b.4 Sleep

When ER[2:0]=101, DM13G will enter sleep type, all outputs will turn off and the IDD of DM13G will drop down to less than 5uA @VCC=5V. This function is especially designed for battery powered display system.

Function Auto Return Table	
Original Function	Auto Return to
Normal	Normal
Smart Outputs Short to GND Detection	Real-Time LED Open Detection
Smart LED Short Detection	Real-Time LED Short Detection
Smart LED Open Detection	Real-Time LED Open Detection
Real-Time LED Short Detection	Real-Time LED Short Detection
Real-Time LED Open Detection	Real-Time LED Open Detection

### Timing Diagram (for global brightness data and open/short selection setting)

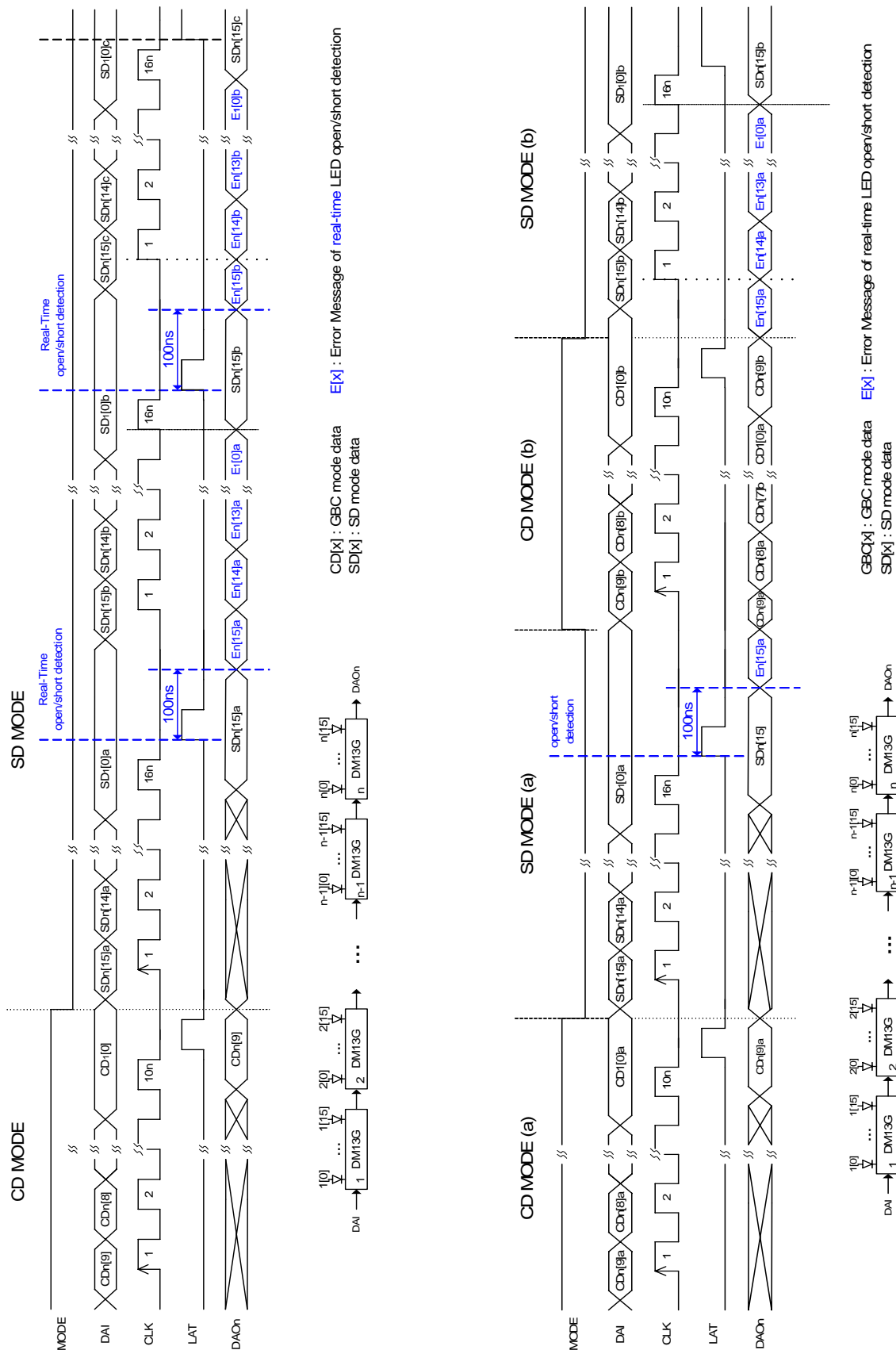

## Outputs Delay

Large in-rush currents will occur when the system activates all the outputs at once. To reduce this effect, DM13G is designed to have a constant unit of delay between outputs. All IOUTs are divided into four groups and every four outputs form a group. For example, IOUT0 ~ IOUT3 form the group1; IOUT4 ~ IOUT7 form the group2. There is no delay between every group. But each IOUT delay in the same group is 3ns @VDD=3.3V (typical).

## Alarm Function

It can detect the operating status by connecting a pull-high resistor to the open-drain ALARM pin. The ALARM pin is kept 'H' for normal conditions, and shifted to 'L' if there is any failure like LED open/short, outputs short to GND, overheating. User can determine the different status from the truth table below:

Error Detection Time		Error Report Time		Status
ER[2:0]	ENB	ENB	ALARM	
don't care	don't care	don't care	H	Normal Operation
111 / 011	L / don't care	L	H→L	LED Open issue
110 / 010	L / don't care	L	H→L	LED Short issue
001	don't care	L	H→L	Outputs Short issue
don't care	don't care	H	H→L	Thermal Alarm or Shutdown

When the latch is high at SD MODE (MODE='L'), the ALARM pin will reset to high level and start to detect once again. It will send out the error report after the rising of the next CLK pulse. If ENB="L", ALARM pin will show out the open/short or output short error report; when ENB="H", ALARM pin will show out the thermal error report. The detection cycle of the alarm signal will continue until it reaches the rising edge of the latch pulse again. Please see the timing diagram below:

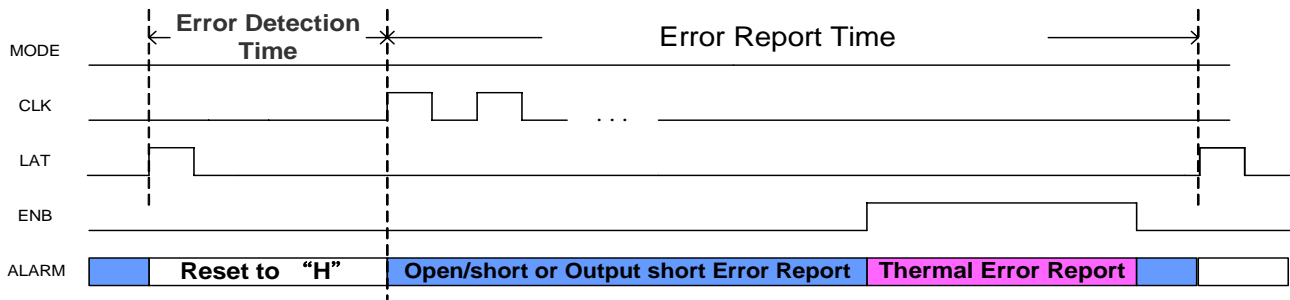

For actual application, the controller could connect all the ALARM pins with one pull-high resistor to simplify circuit designs and feedback loops.

## Thermal Alarm and Shutdown

During operation, when the junction temperature of the IC reaches about 130°C, the ALARM pin will shift to low level and produce a warning signal (ENB="H"). Suggested cooling measures is to start the fan, lower the output currents and etc. If no cooling measures were activated, the junction temperature might continue to rise. Once it reaches approximately above 170°C, it will cause the driver to shutdown all the outputs. Basically, the IC will cool down and return to the safe operating temperature which is approximately below 130°C. The ALARM pin will reset to high level, disable the warning, and restart all the outputs at the same time. Operation in the thermal situation for a long time may cause chip damage permanently.

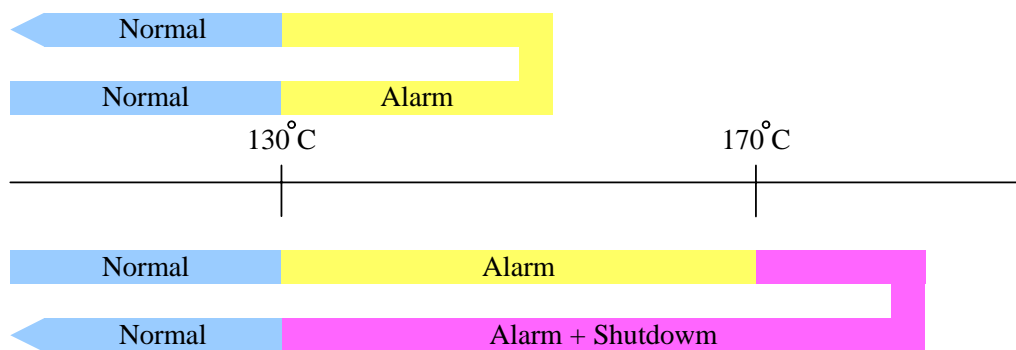

## Ghost Image Elimination

DM13G provide a function of ghost image elimination. When users turn off the output channel, the ghost image elimination circuit will pull up the output voltage to "VLED-0.7V". It can make sure the output channels are fully turned off.

## Power Dissipation

Notice that the power dissipation of a semiconductor chip is limited to its package and ambient temperature, in which the device requires the maximum output current calculated for given operating conditions. The maximum allowable power consumption can be calculated by the following equation:

$$Pd(max)(Watt) = \frac{Tj(junction\ temperature)(max)(\text{ }^{\circ}C) - Ta(ambient\ temperature)(\text{ }^{\circ}C)}{Rth(junction\text{-to}\text{-air\ thermal\ resistance})(\text{ }^{\circ}C/Watt)}$$

The relationship between power dissipation and operating temperature can be refer to the figure below:

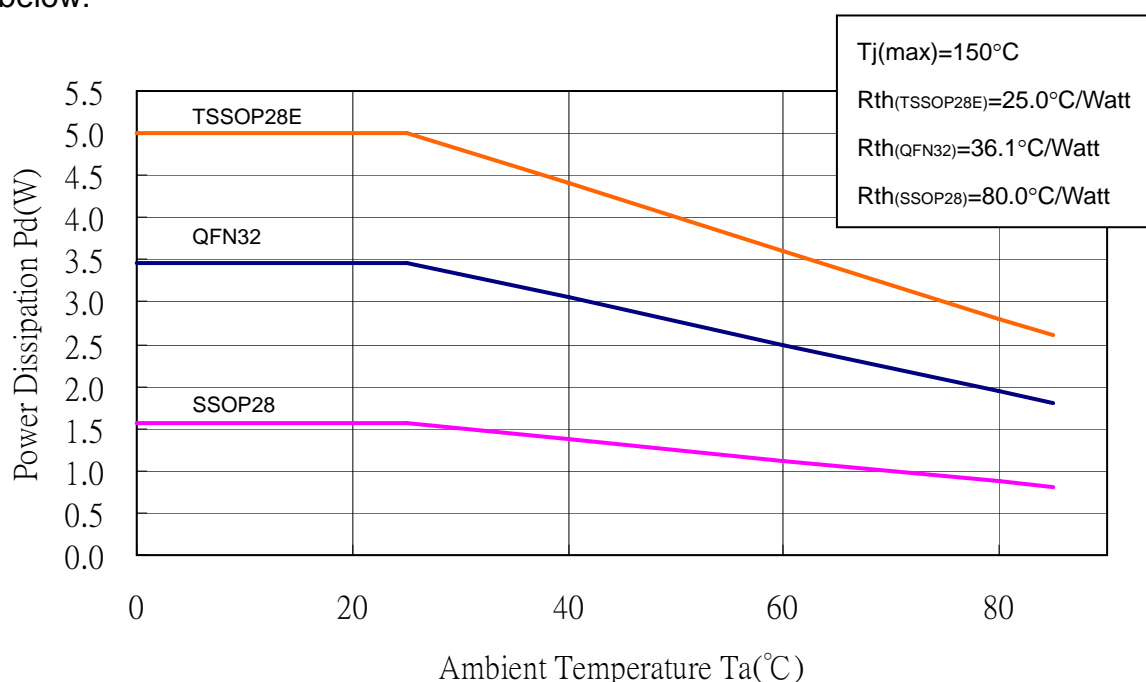

The power consumption of IC can be determined by the following equation and should be less than the maximum allowable power dissipation:

$$Pd(W) = Vcc(V) \times I_{DD}(A) + V_{out0} \times I_{out0} \times Duty0 + \dots + V_{out15} \times I_{out15} \times Duty15 \leq Pd(max)(W)$$

## Package Outline Dimension

### SSOP28

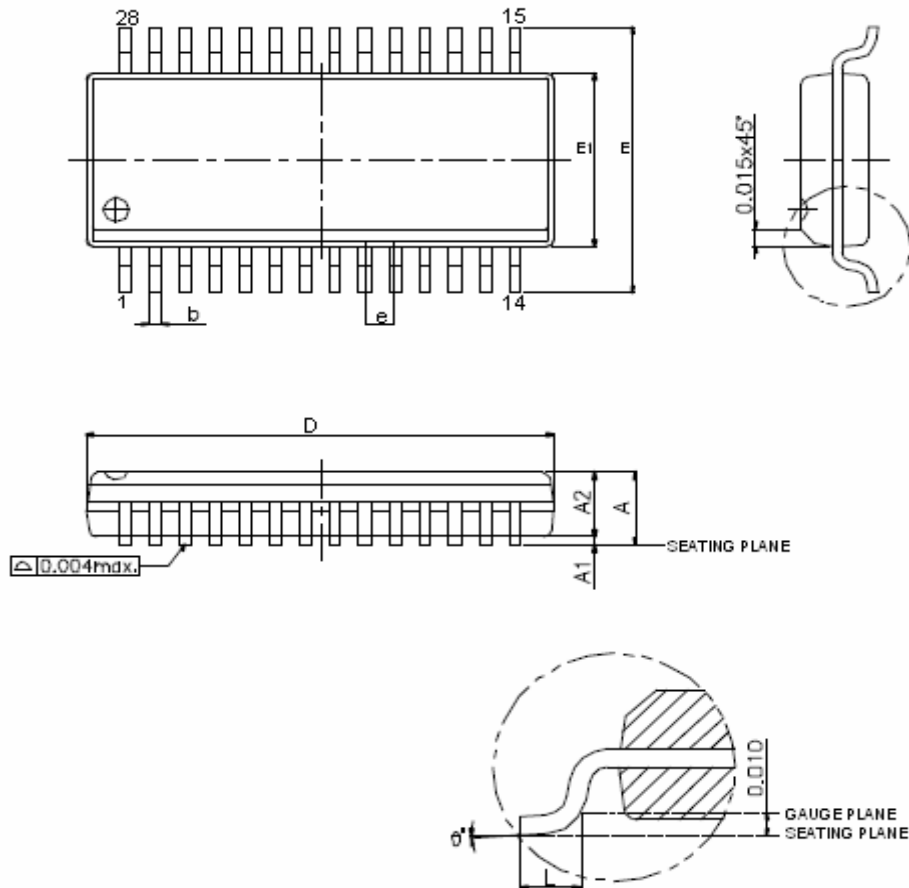

SSOP28 - DIMENSION (mm)			
SYMBOLS	MIN.	NOM.	MAX.
A	1.346	1.550	1.753
A1	0.100	0.177	0.254
A2	-	-	1.500
b	0.200	0.253	0.305
D	9.800	9.904	10.008
E1	3.800	3.900	4.000
e	0.635 BSC		
E	5.791	5.996	6.200
L	0.400	0.835	1.270
$\theta^\circ$	0	-	8

## Package Outline Dimension

### TSSOP28E

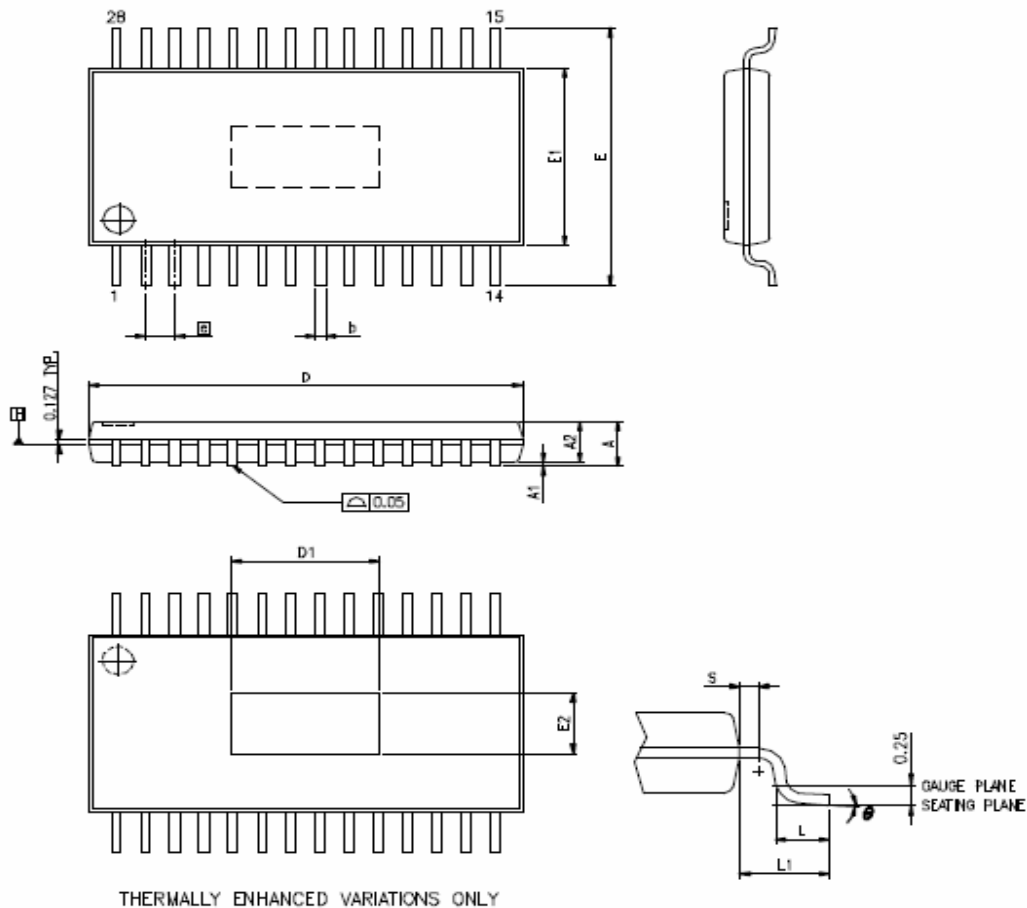

TSSOP28(EP) - DIMENSION (mm)			
SYMBOLS	MIN.	NOM.	MAX.
A	-	-	1.200
A1	0.000	-	0.150
A2	0.800	1.000	1.050
b	0.190	-	0.300
D	9.600	9.700	9.800
E1	4.300	4.400	4.500
E	6.400 BSC		

TSSOP28(EP) - DIMENSION (mm)			
SYMBOLS	MIN.	NOM.	MAX.
e	0.650 BSC		
L1	1.000 REF		
L	0.450	0.600	0.750
S	0.200	-	-
$\theta^\circ$	0	-	8
E2	2.70REF		
D1	4.98REF		

## Package Outline Dimension

### QFN32

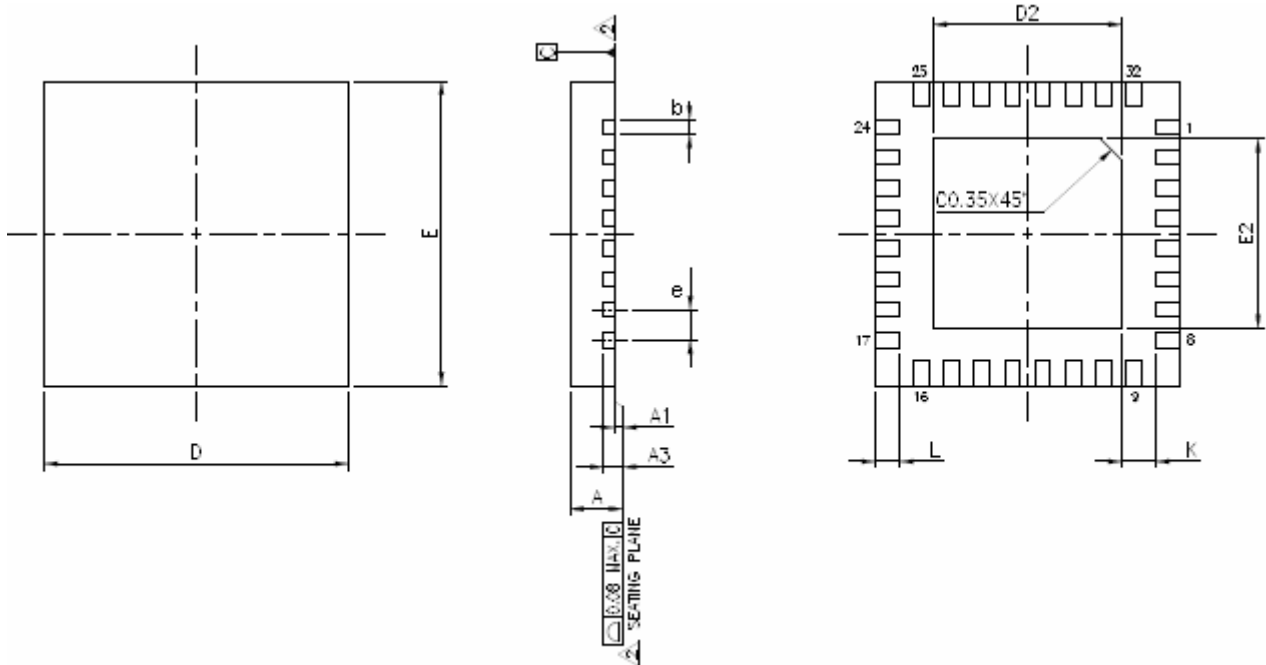

QFN32 - DIMENSION (mm)			
SYMBOLS	MIN.	NOM.	MAX.
A	0.700	0.750	0.800
A1	0.000	0.020	0.050
A3	0.203 REF		
b	0.180	0.250	0.300
D	4.900	5.000	5.100
E	4.900	5.000	5.100
e	0.500 BSC		
L	0.300	0.400	0.500
k	0.200	-	-
EXPOSED PAD			
D2	3.100	3.200	3.300
E2	3.100	3.200	3.300

The products listed herein are designed for ordinary electronic applications, such as electrical appliances, audio-visual equipment, communications devices and so on. Hence, it is advisable that the devices should not be used in medical instruments, surgical implants, aerospace machinery, nuclear power control systems, disaster/crime-prevention equipment and the like. Misusing those products may directly or indirectly endanger human life, or cause injury and property loss.

Silicon Touch Technology, Inc. will not take any responsibilities regarding the misuse of the products mentioned above. Anyone who purchases any products described herein with the above-mentioned intention or with such misused applications should accept full responsibility and indemnify. Silicon Touch Technology, Inc. and its distributors and all their officers and employees shall defend jointly and severally against any and all claims and litigation and all damages, cost and expenses associated with such intention and manipulation.