

DD331

Version : A.002
Issue Date : 2008/12/19
File Name : SP-DD331-A.002.doc
Total Pages : 11

4-Channel Flexible LED Pre-Driver



DD331

4-Channel Flexible LED Pre-Driver

General Description

DD331 is a 4-channel LED pre-driver. It could provide constant-current to drive LED with four N-type MOSFETs and external resistors. The four output enable terminals are designed to drive LED with PWM functions. The maximum voltage and current in LED string are determined by specification of N-type MOSFET.

Features

- ◆ Four independent LED output channels enable terminals, and current adjustment.
- ◆ Flexible in system design:
Maximum constant current output (ILED),
maximum sinking output voltage (VLED), and
minimum output voltage
are determined by the characteristic of N-type MOSFET
- ◆ Fast dimming frequency
(determined by gate capacitance of MOSFET)
- ◆ Supply voltage range: 5V ~ 18V

Applications

- LED architectural or entertainment lighting
- LED general or specialty illumination
- LED backlighting applications

Package Types

SOP16, SSOP16

Block Diagram

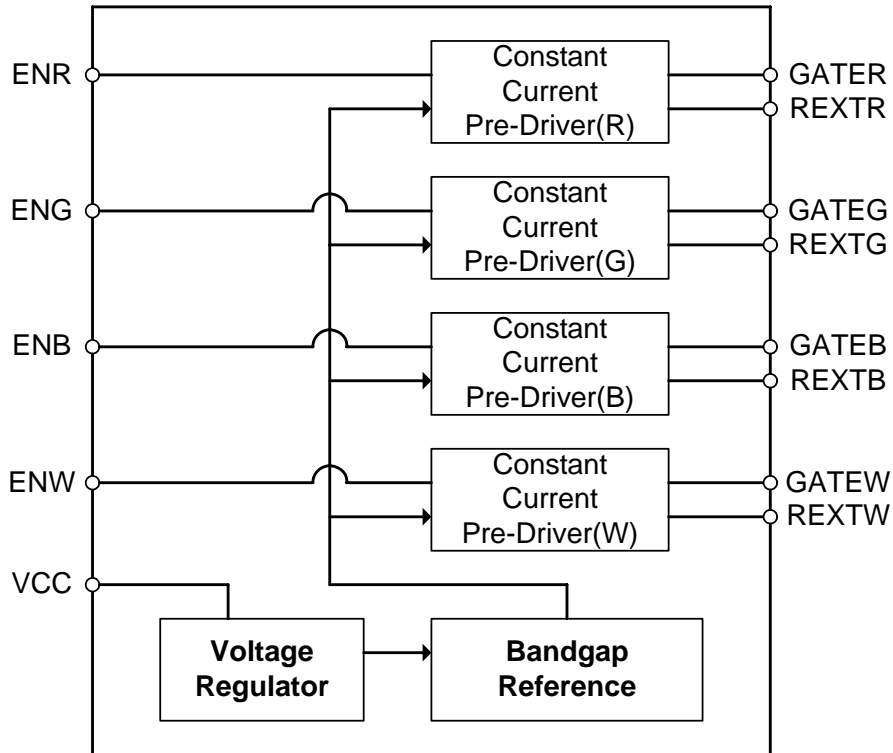

Pin Connection

SOP16 / SSOP16 (Top View)

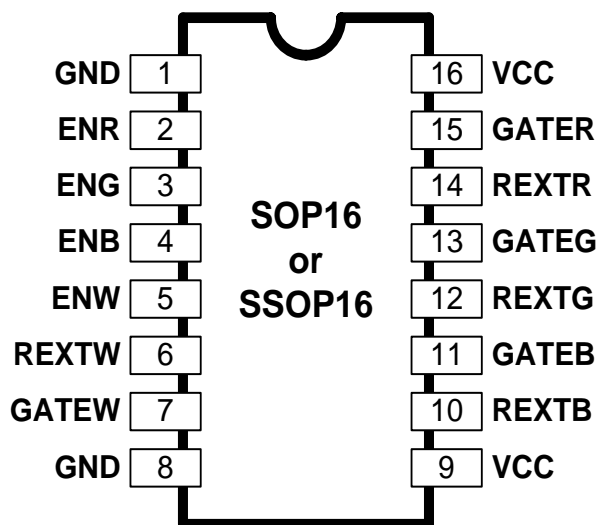



Pin Description

PIN NAME	FUNCTION	SOP16 / TSSOP16 pin number
GND	Ground terminal	1,8
VCC	Power supply terminal	9,16
ENR	Output current enable terminals	2
ENG		3
ENB		4
ENW		5
GATER	External N-type MOSFET gate connection terminals	15
GATEG		13
GATEB		11
GATEW		7
REXTR	External resistors connected between REXT and GND for driver current value setting.	14
REXTG		12
REXTB		10
REXTW		6

Maximum Ratings (Ta=25°C, Tj(max) = 150°C)

CHARACTERISTIC	SYMBOL	RATING	UNIT
Supply Voltage	VCC	-0.3 ~ 18.0	V
Input Voltage	VIN	-0.3 ~ VCC+0.3	
Enable Voltage	VEN ^{*1}	-0.3 ~ 18.0	
GND Terminal Current	IGND	0.5	A
Power Dissipation	Pd	1.7 (SOP16) 1.5 (SSOP16)	W
Thermal Resistance (Junction to Air)	Rth(j-a) ^{*2}	72.1 (SOP16) 82 (SSOP16)	°C/W
Operating Temperature	Top	-40 ~ 85	°C
Storage Temperature	Tstg	-55 ~ 150	

^{*1} VEN could not higher than VCC.

^{*2} Base on JEDEC high conductivity test board (4-layer) simulation.



Recommended Operating Condition

CHARACTERISTIC	SYMBOL	CONDITION	MIN.	TYP.	MAX.	UNIT
Supply Voltage	VCC	—	5	—	18	V
Input Enable Voltage	VIH	VCC = 5V ~ 18V	3.5	—	VCC	V
	VIL		-0.3	—	1	

Electrical Characteristics (Ta = 25°C unless otherwise noted)

CHARACTERISTIC	SYMBOL	CONDITION	MIN.	TYP.	MAX.	UNIT
Input Enable Voltage "H" Level	V _{EN(H)}	VCC = 5 V ~ 18 V	3.5	—	VCC	V
Input Enable Voltage "L" Level	V _{EN(L)}		-0.3	—	1	
V _{rext} Skew (Channel-to-Channel)	IOL1	VCC = 18V R _{ext} = 100Ω	—	—	±3	%
V _{rext} Skew (Chip-to-Chip)	IOL2	External N-mos : VN0606 ^{*1} V _{out} = 18V	—	—	±6	
Supply Voltage Regulation	% / VCC	VCC = 5V ~ 18V	—	0.1	—	
Supply Current	I _{DD1}	VCC = 18V R _{ext} = 100Ω External N-mos : VN0606 V _{out} = 18V	—	—	4.0	mA

AC Characteristics (VCC = 5~18V, Ta = 25°C unless otherwise noted)

CHARACTERISTIC	SYMBOL	CONDITION	MIN.	TYP.	MAX.	UNIT
ENR,ENG,ENB,ENW Pulse Width	twEN	R _{ext} = 100Ω External N-mos : VN0606	1	—	—	ms

*1 The external N-mos VN0606 is just for reference, users can choose other kind external N-mos for their application.

Switching Characteristics ($V_{CC} = 18V$, $T_a = 25^\circ C$ unless otherwise noted)

CHARACTERISTIC		SYMBOL	CONDITION	MIN.	TYP.	MAX.	UNIT
Propagation Delay (‘L’ to ‘H’)	ENR-to-GATER	tpLH	$V_{IH} = V_{CC}$ $V_{IL} = GND$ $R_{r\text{ext}} = 5 \Omega$ $V_L = 18 V$	—	20	—	ns
	ENG-to-GATEG						
	ENR-to-GATEB						
	ENW-to-GATEW						
Propagation Delay (‘H’ to ‘L’)	ENR-to-GATER	tpHL	$R_L = 0.18 K\Omega$ $C_L = 13 pF$ External N-mos : VN0606	—	125	—	ns
	ENG-to-GATEG						
	ENR-to-GATEB						
	ENW-to-GATEW						

Switching Characteristics ($V_{CC} = 5V$, $T_a = 25^\circ C$ unless otherwise noted)

CHARACTERISTIC		SYMBOL	CONDITION	MIN.	TYP.	MAX.	UNIT
Propagation Delay (‘L’ to ‘H’)	ENR-to-GATER	tpLH	$V_{IH} = V_{CC}$ $V_{IL} = GND$ $R_{r\text{ext}} = 5 \Omega$ $V_L = 18 V$	—	25	—	ns
	ENG-to-GATEG						
	ENR-to-GATEB						
	ENW-to-GATEW						
Propagation Delay (‘H’ to ‘L’)	ENR-to-GATER	tpHL	$R_L = 0.18 K\Omega$ $C_L = 13 pF$ External N-mos : VN0606	—	124	—	ns
	ENG-to-GATEG						
	ENR-to-GATEB						
	ENW-to-GATEW						

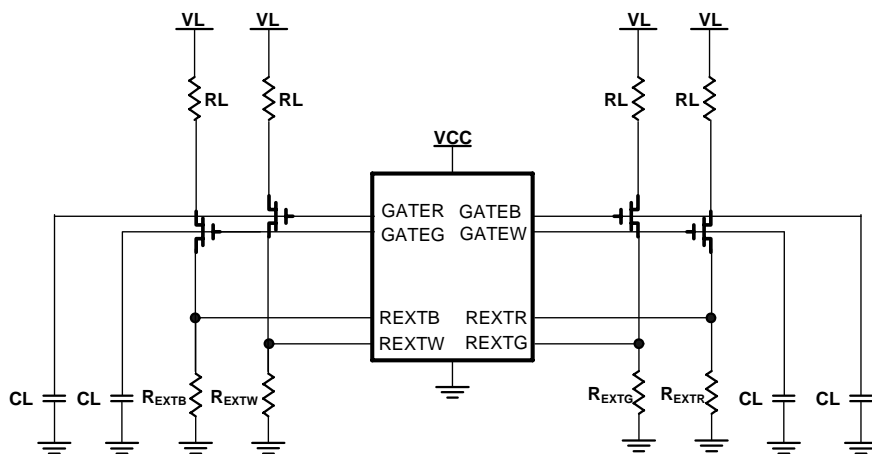

Switching Characteristics Test Circuit

Timing Diagram

ENG, ENR, ENB, ENW to GATER, GATEG, GATEB, GATEW

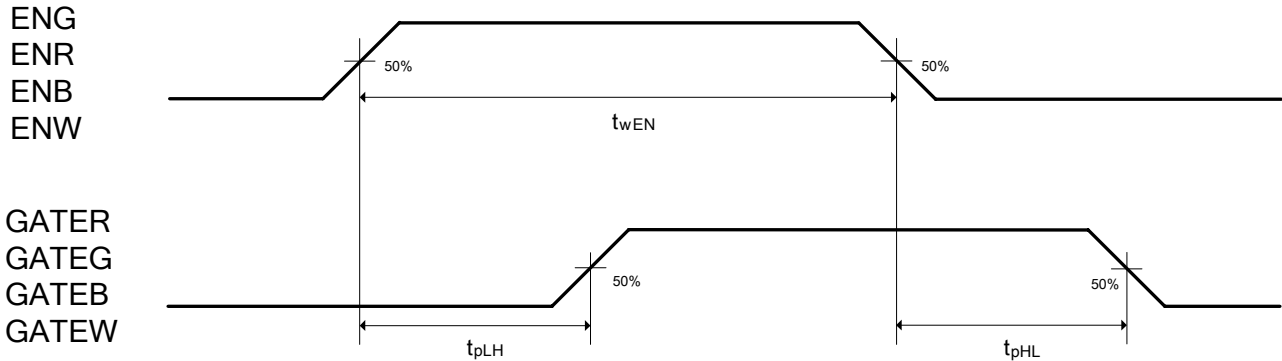

Constant-Current Output

The constant-current value of each output channels is set by a N-type MOSFET and an external resistor connected between the REXT(R, G, B, W) pin and GND individually. Varying the resistor value can adjust the current. Notice that the output current is a little increasing or decreasing until the device temperature and ambient temperature are balance. Approximate output current value can be calculated by following equation:

I_{out}	5	10	20	40	80	160	220
M	883.1	967.2	990	10128	1044.6	1115.6	1478.8

$$I_{out} = 0.52 / R_{ext} * M$$

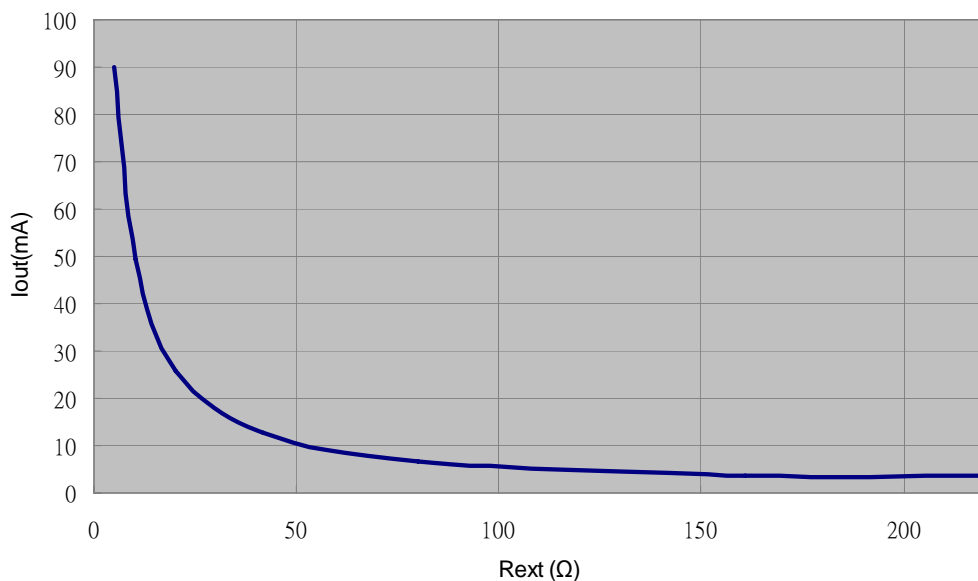

Typical Application

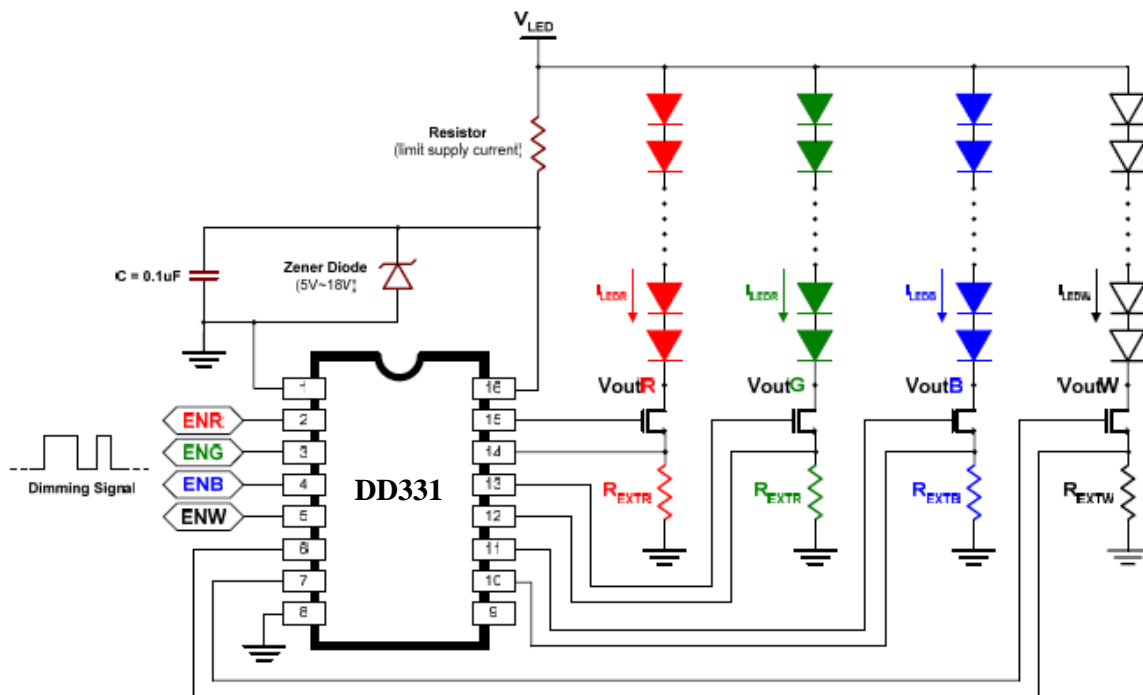

Application Notice

Notice the R_{ext} applies to lower than 5Ω , the wire resistance (R_{wire}) will affect I_{out} a lot. For example, when $R_{ext}=5 \Omega$, $I_{out}=104mA$, if $R_{wire}=1 \Omega$, then I_{out} will decrease 1.96%. Due to large current flow through R_{ext} , it needs high power resistor to apply to prevent element burn out issue.

Dissipation Ratings

PACKAGE	POWER DISSIPATION ($T_{j_max}=150^{\circ}C$)	THERMAL RESISTANCE ($R_{th(junction-to-air)}$, $T_a=25^{\circ}C$)
SOP16	1.7 W	72.1 $^{\circ}C/W$
SSOP16	1.5 W	82 $^{\circ}C/W$

Power Dissipation

Notice that the power dissipation of a semiconductor chip is limited to its package and ambient temperature, in which the device requires the maximum output current calculated for given operating conditions. The maximum allowable power consumption can be calculated by the following equation:

$$P_{d(max)}(Watt) = \frac{T_j(\text{junction temperature})(max)(^{\circ}C) - T_a(\text{ambient temperature})(^{\circ}C)}{R_{th}(\text{junction-to-air thermal resistance})(^{\circ}C/Watt)}$$

Package Outline Dimension

SOP16

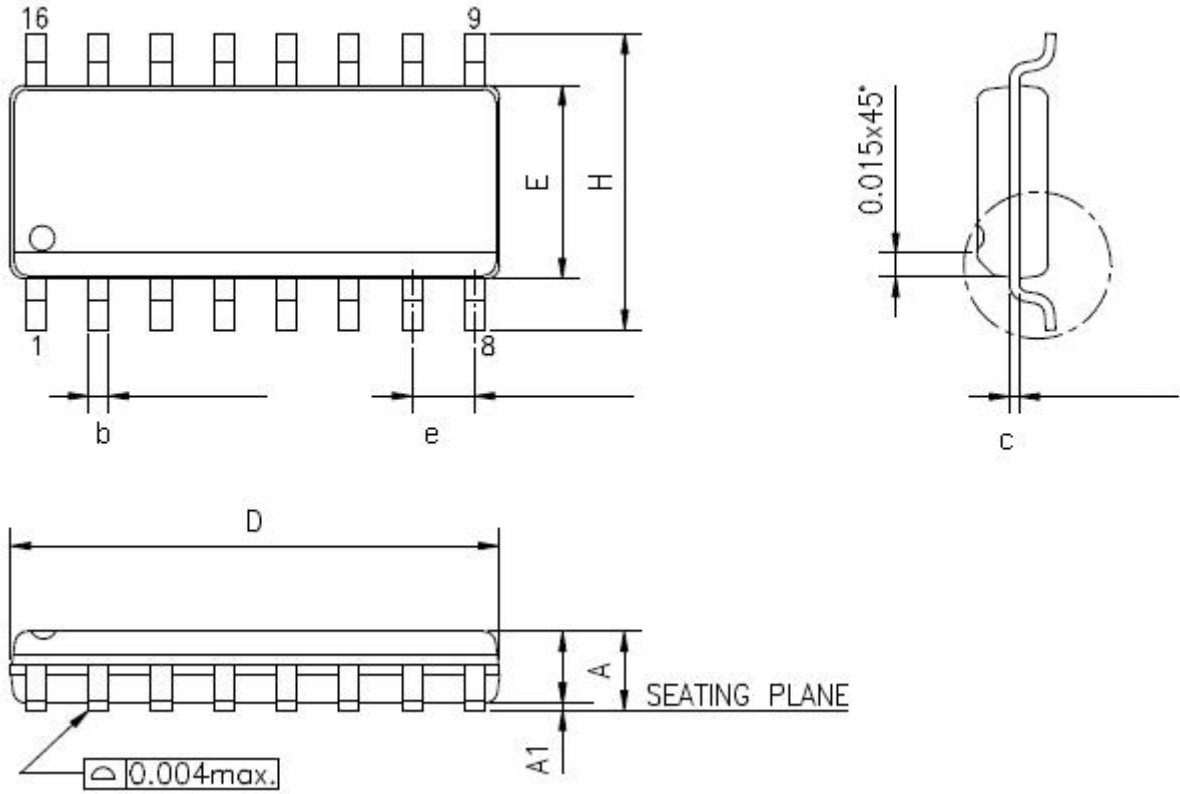

SOP16-150mil		mm	
SYMBOLS	MIN.	TYP.	MAX.
A	1.346	-	1.753
A1	0.051	-	0.250
b	0.330	-	0.510
c	0.190	-	0.250
D	9.800	-	10.008
E	3.800	-	4.000
e	1.270 BSC		
H	5.791	-	6.200
L	0.400	-	1.270
θ°	0	-	8

Package Outline Dimension

SSOP16

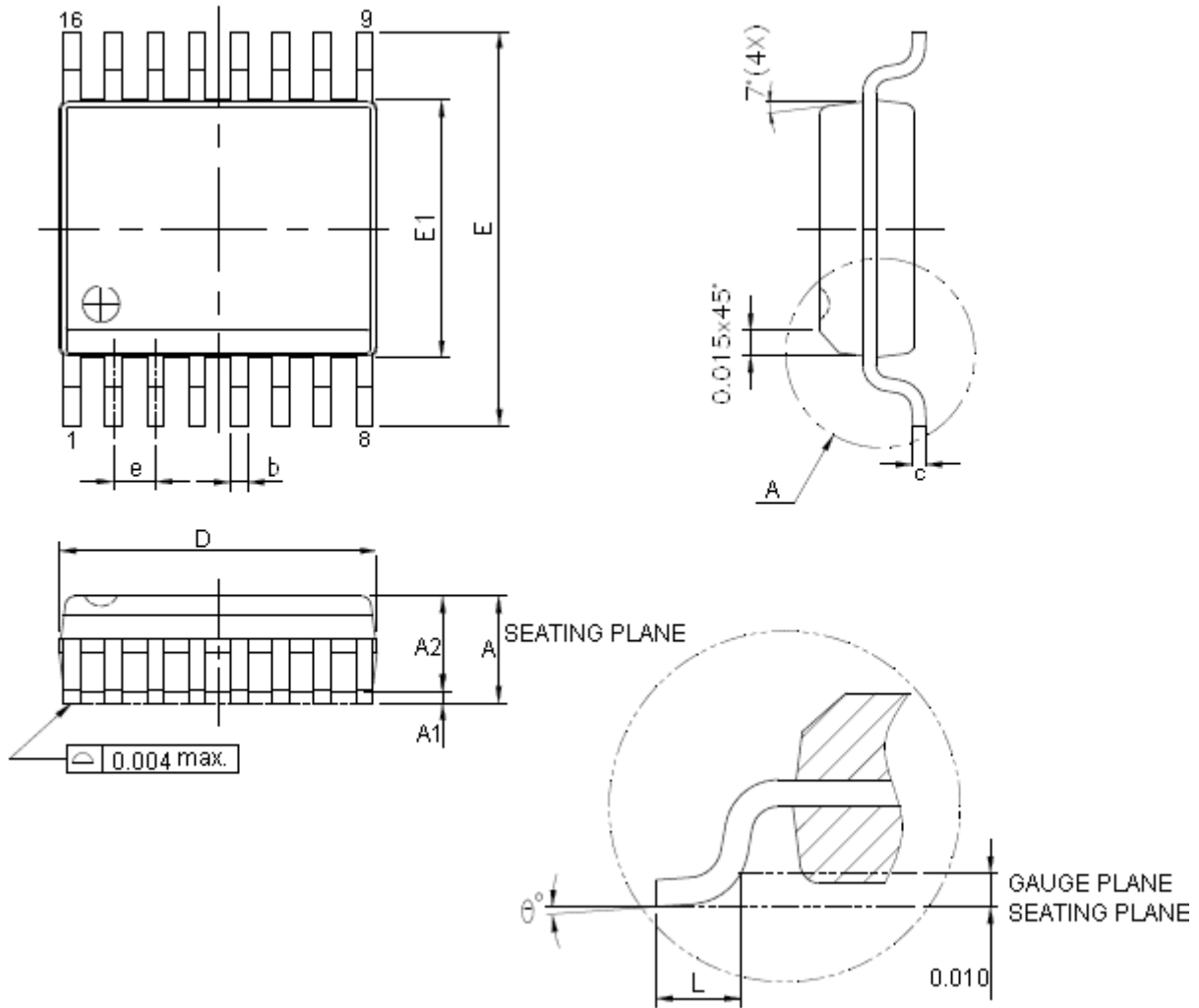

SSOP16		mm	
SYMBOLS	MIN.	TYP.	MAX.
A	1.346	-	1.753
A1	0.102	-	0.254
A2	1.245	-	1.499
b	0.203	-	0.305
c	0.178	-	0.254
D	4.801	4.902	5.004
E	5.791	5.994	6.198
e	0.635 BSC		
E1	3.810	3.912	3.988
L	0.406	-	1.270
θ°	0	-	8



The products listed herein are designed for ordinary electronic applications, such as electrical appliances, audio-visual equipment, communications devices and so on. Hence, it is advisable that the devices should not be used in medical instruments, surgical implants, aerospace machinery, nuclear power control systems, disaster/crime-prevention equipment and the like. Misusing those products may directly or indirectly endanger human life, or cause injury and property loss.

Silicon Touch Technology, Inc. will not take any responsibilities regarding the misuse of the products mentioned above. Anyone who purchases any products described herein with the above-mentioned intention or with such misused applications should accept full responsibility and indemnify. Silicon Touch Technology, Inc. and its distributors and all their officers and employees shall defend jointly and severally against any and all claims and litigation and all damages, cost and expenses associated with such intention and manipulation.