

Ø2.50mm [0.098in]

M3X5 LG, THREADED INSERT (4) PLACES.
M4X8 LG, THREADED INSERT (4) PLACES.

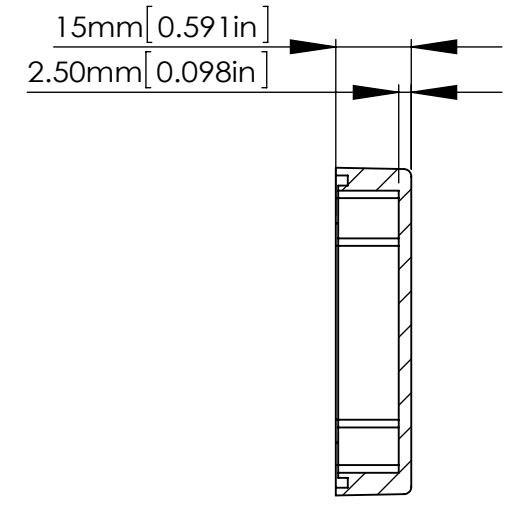

SECTION B-B
SCALE 2:3

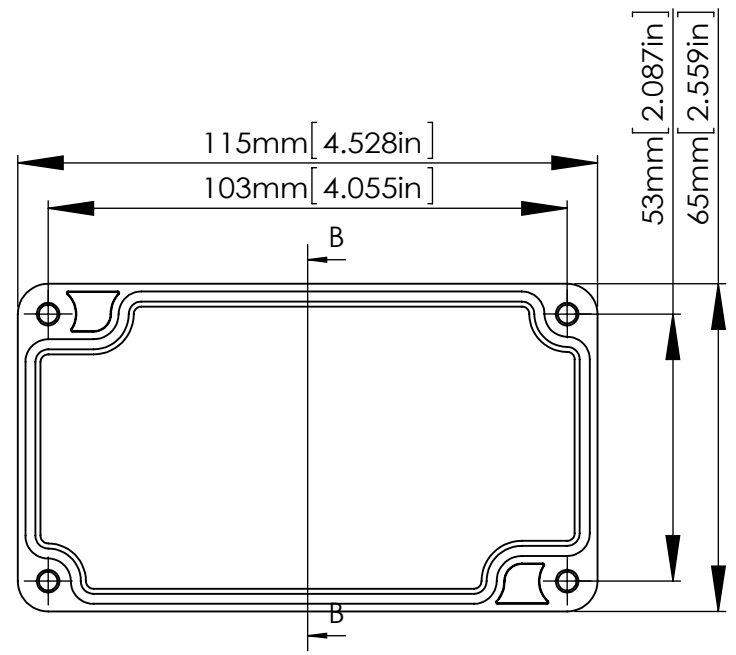
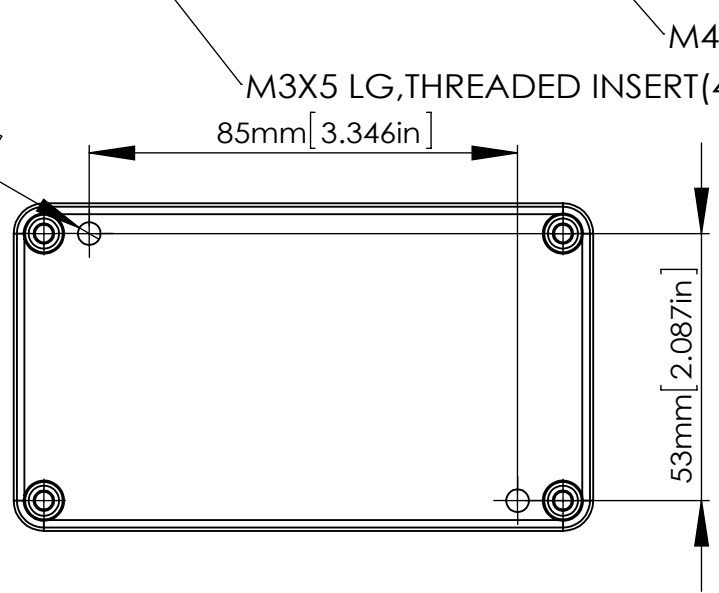

Ø4.50mm [0.177in]

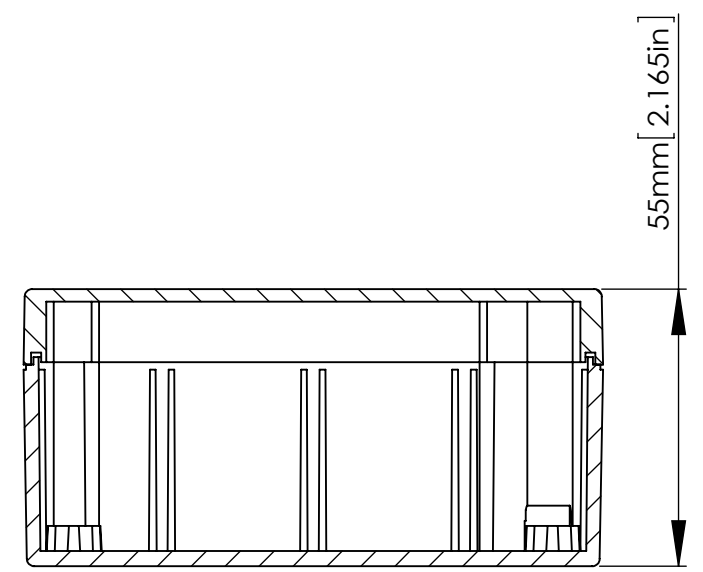

ASSEMBLY

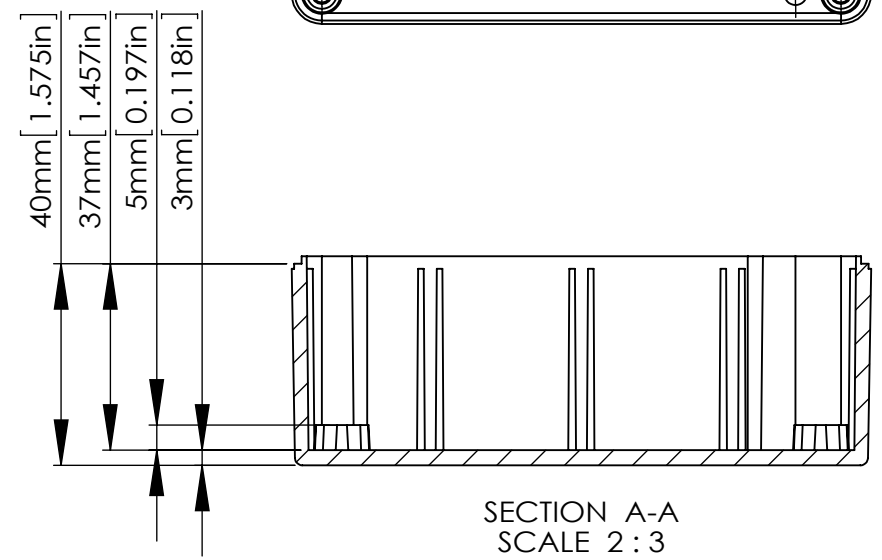

SECTION A-A
SCALE 2:3

According to ISO 2768-m	
Measuring DIM=L	Tolerances
0.5<L<=3.0mm	±0.1mm
3.0<L<=6.0 mm	±0.1mm
6.0<L<=30.0 mm	±0.2mm
30.0<L<=120.0 mm	±0.3mm
120.0<L<=400.0 mm	±0.5mm
400.0<L<=1000.0 mm	±0.8mm

宣又實業有限公司 GAINTA INDUSTRIES LTD.	繪圖	DRA'D BY	日期	DATE	材質	MATE.	圖名TITLE:	圖號DWG NO:	版次REVISED:
		JACKY	2024/07/17		PC/ABS		G205;G308		F