

1SS373

SILICON EPITAXIAL SCHOTTKY BARRIER DIODE

High Speed Switching Application

Features

- Low forward voltage:
 $V_F = 0.23V$ (typ.) @ $I_F = 5mA$

PINNING

PIN	DESCRIPTION
1	Cathode
2	Anode

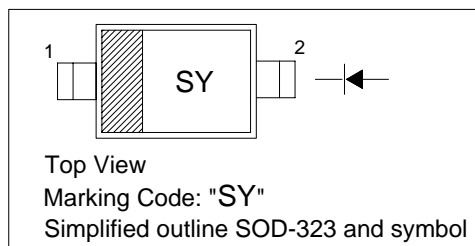

Absolute Maximum Ratings ($T_j = 25^\circ C$)

Parameter	Symbol	Value	Unit
Maximum (peak) Reverse Voltage	V_{RM}	15	V
Reverse Voltage	V_R	10	V
Maximum (peak) Forward Current	I_{FM}	200	mA
Average Forward Current	I_O	100	mA
Surge Current (10ms)	I_{FSM}	1	A
Power Dissipation	P_{tot}	150	mW
Junction Temperature	T_J	125	°C
Storage Temperature Range	T_s	-55 to +125	°C
Operating Temperature Range	T_{opr}	-40 to +100	°C

Characteristics at $T_j = 25^\circ C$?

Parameter	Test Conditions	Symbol	Min	Typ	Max	Unit
Forward Voltage	$I_F = 1mA$	V_F	-	0.18	-	V
	$I_F = 5mA$	V_F	-	0.23	0.30	V
	$I_F = 100mA$	V_F	-	0.35	0.50	V
Reverse Current	$V_R = 10V$	I_R	-	-	20	μA
Total Capacitance	$f = 1MHz$	C_T	-	20	40	pF

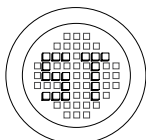

®

РАДИОТЕХ

Тел.: (495) 795-0805
 Факс: (495) 234-1603
 Эл. почта: info@rct.ru
 Веб: www.rct.ru

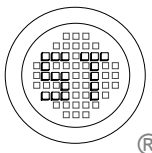
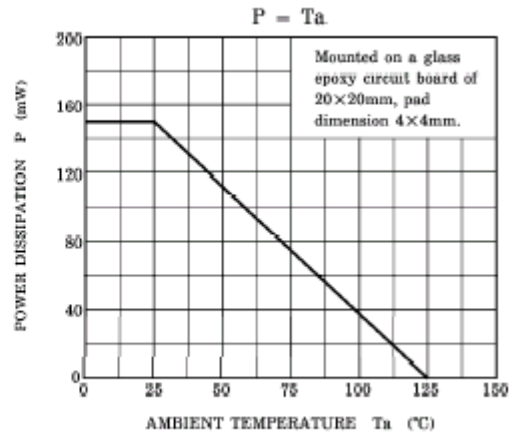
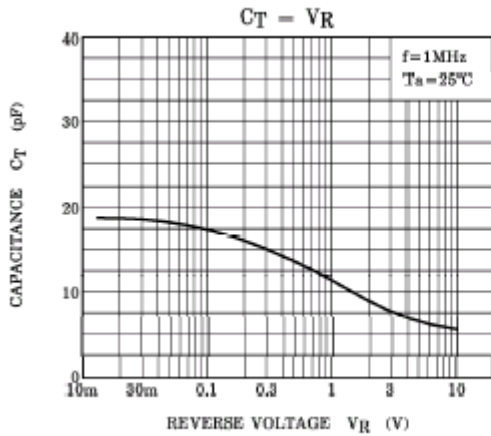
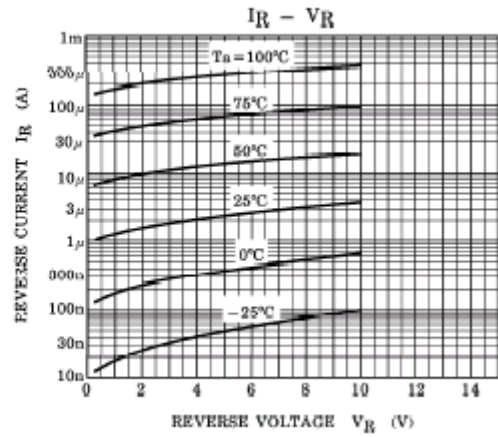
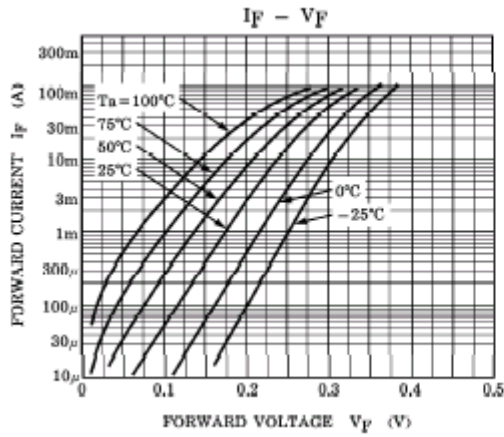

SEMTECH ELECTRONICS LTD.

(Subsidiary of Semtech International Holdings Limited, a company listed on the Hong Kong Stock Exchange, Stock Code: 724)

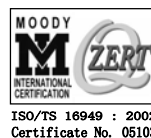

1SS373

PACKAGE OUTLINE

Plastic surface mounted package; 2 leads

SOD-323

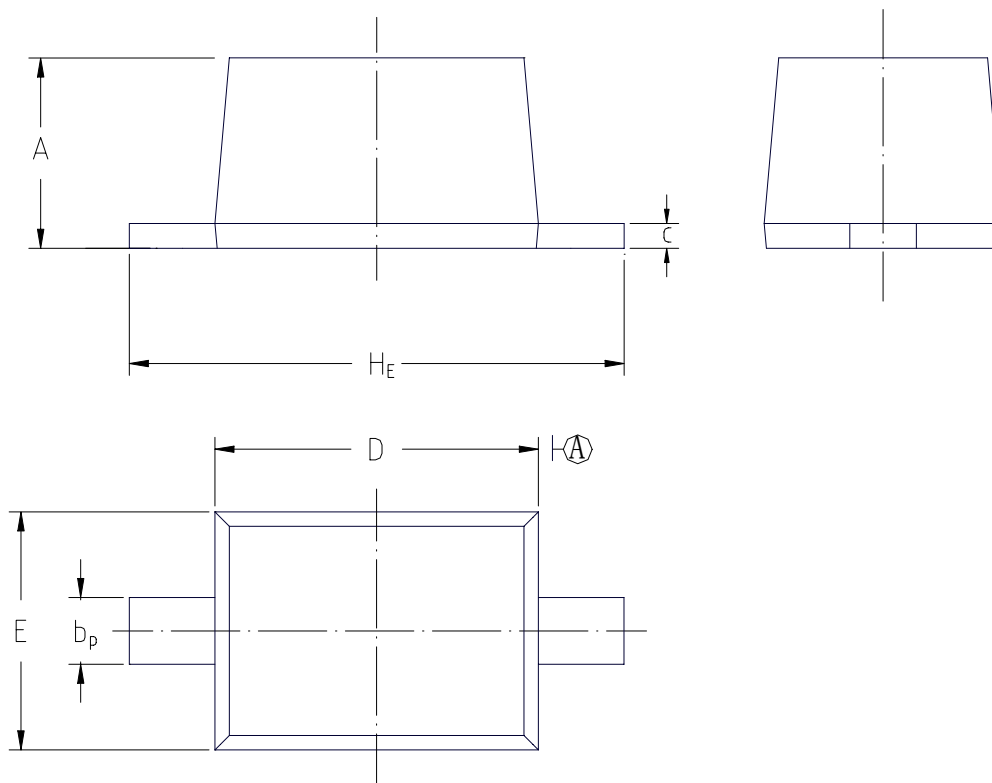

UNIT	A	b_p	c	D	E	H_E
mm	1.10 0.80	0.40 0.25	0.15 0.00	1.80 1.60	1.35 1.15	2.80 2.30

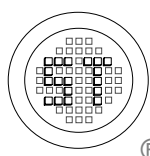

SEMTECH ELECTRONICS LTD.

(Subsidiary of Semtech International Holdings Limited, a company listed on the Hong Kong Stock Exchange, Stock Code: 724)



ISO/TS 16949 : 2002
Certificate No. 05103



ISO 14001
Certificate No. 7116



ISO 9001 : 2000
Certificate No. 550-1559-04-002-04

Dated : 30/10/2004