

1N5817WB-1N5819WB

1.0A SURFACE MOUNT SCHOTTKY BARRIER DIODE

PINNING

PIN	DESCRIPTION
1	Cathode
2	Anode

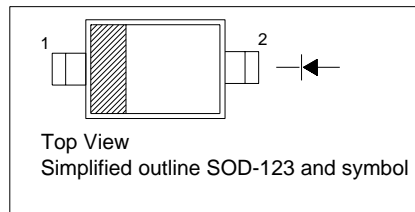

Marking:

1N5817WB Marking Code: A0

1N5818WB Marking Code: ME

1N5819WB Marking Code: SR

Absolute Maximum Ratings (T_a = 25°C)

	Symbol	Value	Unit
DC Reverse Voltage	V _R	20	V
1N5817WB		30	
1N5818WB		40	
Average Rectified Output Current	I _O	1.0	A
Power Dissipation	P _{tot}	450	mW
Operating Temperature Range	T _j	-55 to +150	°C
Storage Temperature Range	T _s	-55 to +150	°C

Characteristics at T_a = 25°C

Parameter		Symbol	Min.	Typ.	Max.	Unit
Reverse Breakdown Voltage at I _R =1mA	1N5817WB	V _{BR}	20	-	-	V
	1N5818WB		30	-	-	
	1N5819WB		40	-	-	
Reverse Voltage Leakage Current at V _R =20V at V _R =30V at V _R =40V at V _R =4V at V _R =6V	1N5817WB	I _R	-	-	1	mA
	1N5818WB		-	-	1	
	1N5819WB		-	-	1	
	1N5819WB		-	-	0.05	
	1N5819WB		-	-	0.075	
Forward Voltage at I _F =0.1A at I _F =1A at I _F =3A	1N5819WB	V _F	-	-	0.45	V
	1N5817WB		-	-	0.45	
	1N5818WB		-	-	0.55	
	1N5819WB		-	-	0.6	
	1N5817WB		-	-	0.75	
	1N5818WB		-	-	0.875	
Diode Capacitance at V _R =4V, f=1MHz		C _D	-	-	120	pF

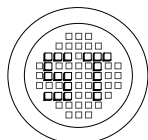

®

РАДИОТЕХ

Тел.: (495) 795-0805
Факс: (495) 234-1603
Эл. почта: info@rct.ru
Веб: www.rct.ru

1N5817WB-1N5819WB

PACKAGE OUTLINE

Plastic surface mounted package; 2 leads

SOD-123

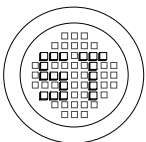
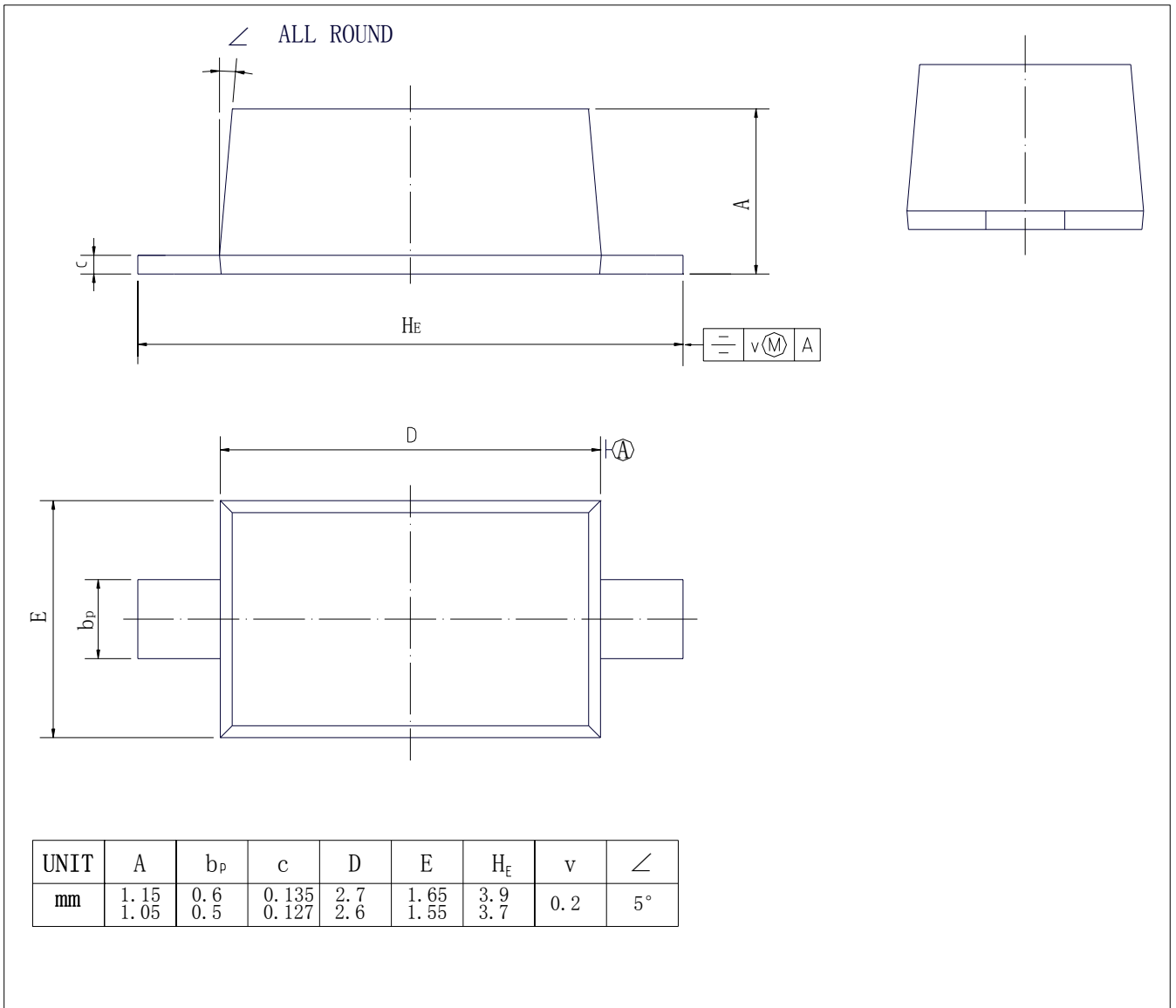

SEMTECH ELECTRONICS LTD.

(Subsidiary of Semtech International Holdings Limited, a company listed on the Hong Kong Stock Exchange, Stock Code: 724)

®

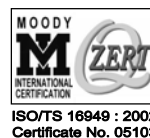

Dated : 14/10/2005