

# 1N5817W

## 1.0A SURFACE MOUNT SCHOTTKY BARRIER DIODE

### Features:

- Schottky Barrier Chip
- Guard Ring Die Construction for Transient Protection
- Low Power Loss, High Efficiency
- High Surge Capability
- High Current Capability and Low Forward Voltage Drop
- For Use in Low Voltage, High Frequency Inverters, Free Wheeling, and Polarity Protection Application.

### PINNING

PIN	DESCRIPTION
1	Cathode
2	Anode

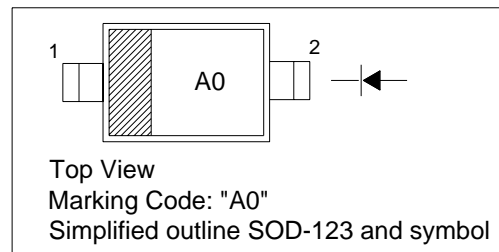

### Mechanical Data:

Case: SOD-123, Plastic

Terminals : Solderable per MIL-STD-202, Method 208

Polarity : Cathode Band

### Absolute Maximum Ratings ( $T_a = 25^\circ\text{C}$ )

	Symbol	Value	Unit
Peak Repetitive Reverse Voltage	$V_{RRM}$	20	V
Working Peak Reverse Voltage at $I_R=1.0\text{mA}$	$V_{RWM}$	20	V
DC Blocking Voltage	$V_R$	20	V
RMS Reverse Voltage	$V_{R(RMS)}$	14	V
Average Rectified Output Current at $T_L=90^\circ\text{C}$	$I_O$	1.0	A
Power Dissipation	$P_{tot}$	450	mW
Non-Repetitive Peak Forward Surge Current 8.3ms single half sine-wave superimposed on rated load (JEDEC Method)	$I_{FSM}$	25	A
Typical Thermal Resistance Junction to Ambient	$R_{\theta JA}$	222	? /W
Operating Temperature Range	$T_j$	-65 to +125	?
Storage Temperature Range	$T_s$	-65 to +150	?

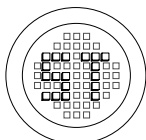

®

РАДИОТЕХ

Тел.: (495) 795-0805  
Факс: (495) 234-1603  
Эл. почта: info@rct.ru  
Веб: www.rct.ru

# 1N5817W

## Characteristics at $T_{amb} = 25^{\circ}\text{C}$

		Symbol	Min.	Typ.	Max.	Unit
Forward Voltage (Note 1)	at $I_F = 0.1\text{A}$	$V_{FM}$	-	-	0.32	V
	at $I_F = 1.0\text{A}$	$V_{FM}$	-	-	0.45	V
	at $I_F = 3.0\text{A}$	$V_{FM}$	-	-	0.75	V
Reverse Breakdown Voltage	at $I_R = 1.0\text{mA}$	$V_{(BR)R}$	20	-	-	V
Reverse Leakage Current (Note 1)	at $V_R = 20\text{V}$	$I_{RM}$	-	-	1	mA
	at $V_R = 20\text{V}, T_A = 100^{\circ}\text{C}$		-	-	10	mA
	at $V_R = 2\text{V}$		-	10	50	$\mu\text{A}$
	at $V_R = 2\text{V}, T_A = 100^{\circ}\text{C}$		-	1	2	mA
	at $V_R = 3\text{V}$		-	15	75	$\mu\text{A}$
	at $V_R = 3\text{V}, T_A = 100^{\circ}\text{C}$		-	1.5	3	mA
Typical Junction Capacitance at $V_R = 2\text{V}, f = 1\text{MHz}$		$C_J$	-	110	-	pF

### Notes:

1. Pulse Test: Pulse width  $\leq 200 \mu\text{s}$ , Duty Cycle  $\leq 2\%$ .

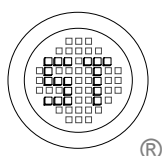

## SEMTECH ELECTRONICS LTD.

(Subsidiary of Semtech International Holdings Limited, a company listed on the Hong Kong Stock Exchange, Stock Code: 724)



ISO/TS 16949 : 2002  
Certificate No. 05103



ISO 14001  
Certificate No. 7116



ISO 9001 : 2000  
Certificate No. 555-199-01-00-104

Dated : 24/11/2004

# 1N5817W

## PACKAGE OUTLINE

Plastic surface mounted package; 2 leads

SOD-123

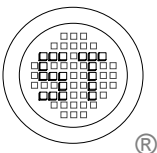
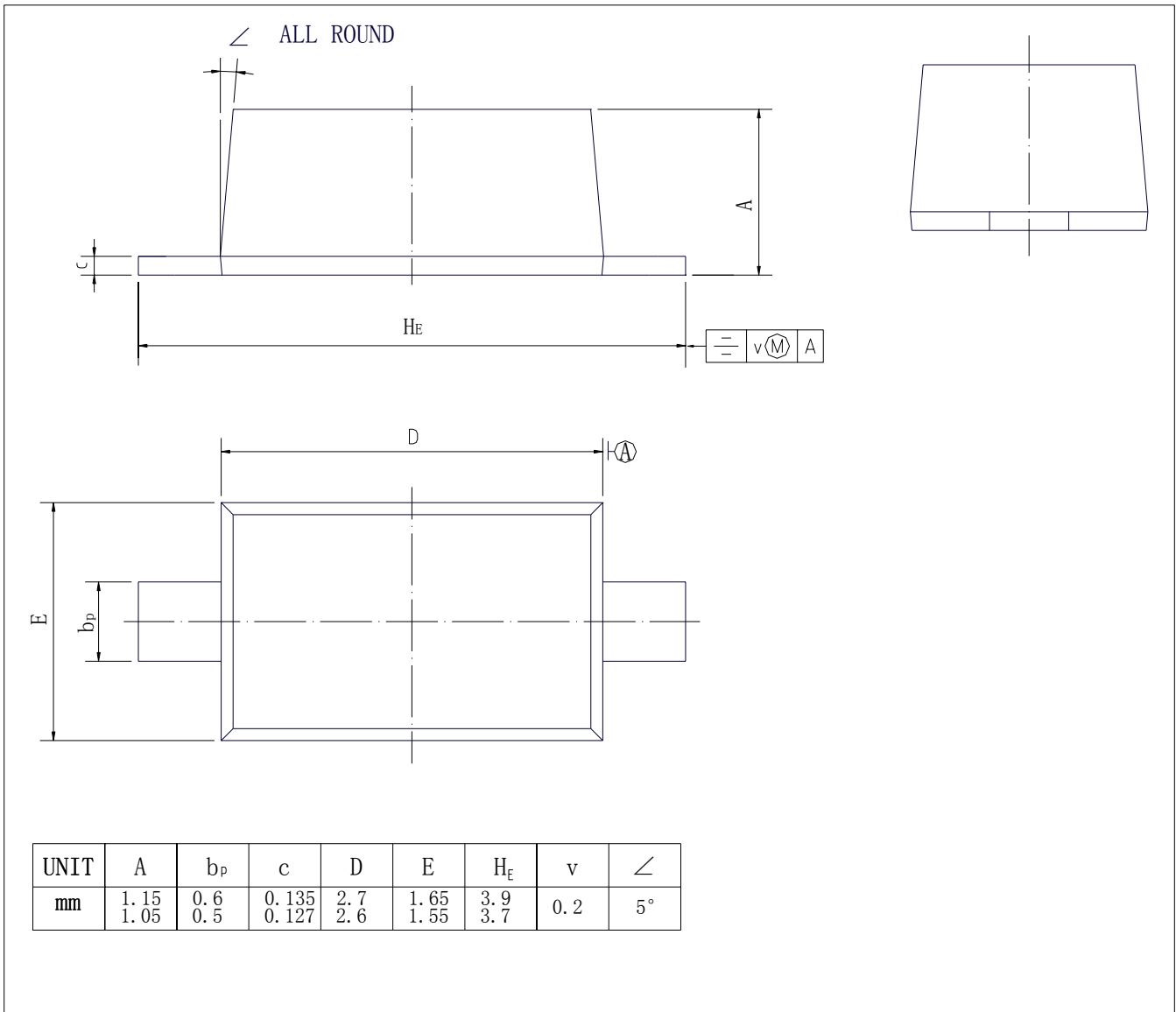

**SEMTECH ELECTRONICS LTD.**

(Subsidiary of Semtech International Holdings Limited, a company listed on the Hong Kong Stock Exchange, Stock Code: 724)



ISO/TS 16949 : 2002  
Certificate No. 05103



ISO 14001  
Certificate No. 7116



ISO 9001 : 2000  
Certificate No. 555-199-01-907-104

Dated : 24/11/2004