

# 1N-SS119

## SILICON EPITAXIAL PLANAR DIODE for High Speed Switching

### Features

- Low capacitance. ( $C = 3.0\text{pF max}$ )
- Short reverse recovery time. ( $t_{rr} = 3.5\text{ns max}$ )
- Small glass package (MHD) enables easy mounting and high reliability.

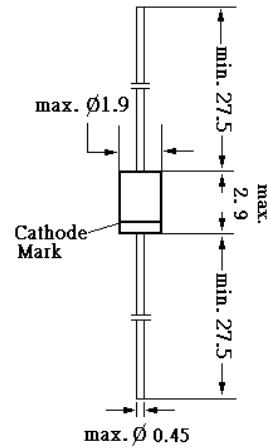

Glass case JEDEC DO-34

Dimensions in mm

Weight approx. 0.092g

### Absolute Maximum Ratings ( $T_a = 25^\circ\text{C}$ )

	Symbol	Value	Unit
Peak reverse voltage	$V_{RM}$	35	V
Reverse voltage	$V_R$	30	V
Average rectified current	$I_o$	150	mA
Peak forward current	$I_{FM}$	450	mA
Non-Repetitive peak forward surge current	$I_{FSM}^*$	1	A
Power dissipation	$P_d$	250	mW
Junction temperature	$T_j$	175	$^\circ\text{C}$
Storage temperature range	$T_s$	-65 to +175	$^\circ\text{C}$

Note: Within 1s forward surge current.

### Characteristics at $T_a = 25^\circ\text{C}$

	Symbol	Min.	Typ.	Max.	Unit
Forward Voltage at $I_F = 10\text{mA}$	$V_F$	-	-	0.8	V
Reverse current at $V_R = 30\text{V}$	$I_R$	-	-	0.1	$\mu\text{A}$
Capacitance at $V_R = 1\text{V}$ , $f = 1\text{MHz}$	$C$	-	-	3	pF
Reverse recovery time at $I_F = 10\text{mA}$ , $V_R = 6\text{V}$ , $R_L = 50\Omega$	$t_{rr}^*$	-	-	3.5	ns

Note: Reverse recovery time test circuit

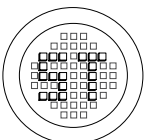

®

**РАДИОТЕХ**

Тел.: (495) 795-0805  
Факс: (495) 234-1603  
Эл. почта: info@rct.ru  
Веб: www.rct.ru

Fig.1-Forward current Vs. Forward voltage

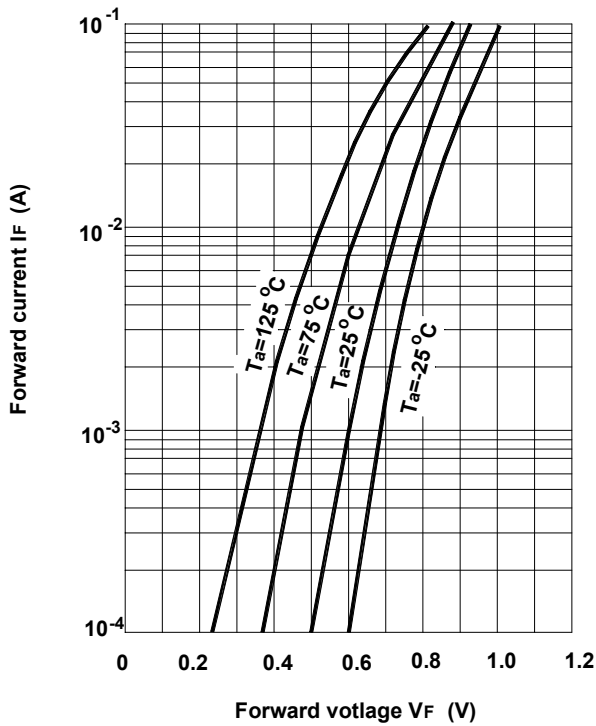

Fig.2- Reverse current Vs. Reverse voltage

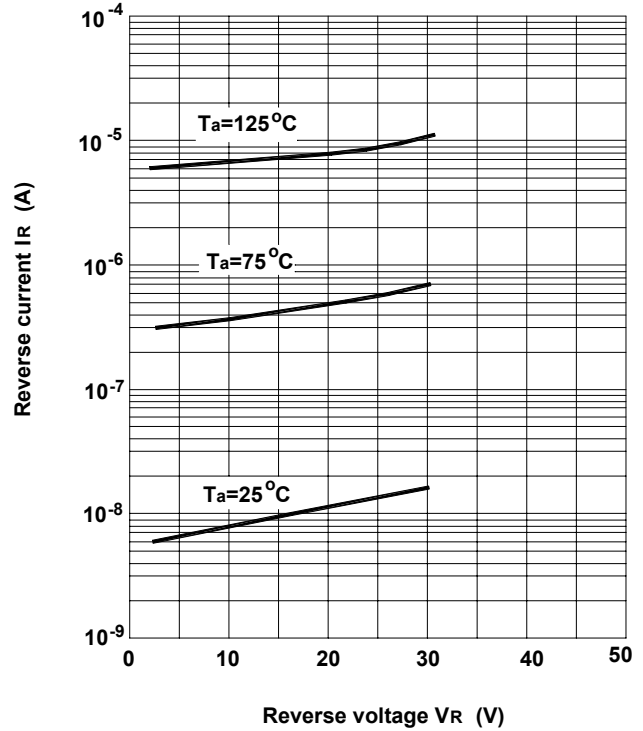
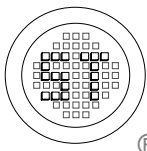
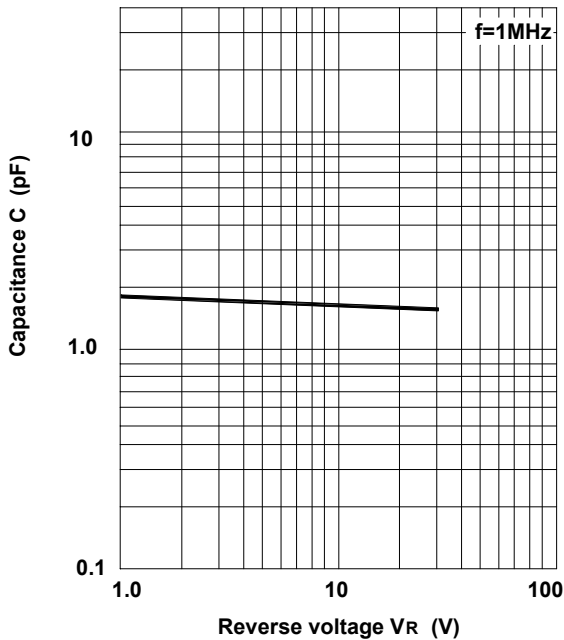

Fig.3- Capacitance Vs. Reverse voltage



## SEMTECH ELECTRONICS LTD.

(Subsidiary of Semtech International Holdings Limited, a company listed on the Hong Kong Stock Exchange, Stock Code: 724)



ISO/TS 16949 : 2002  
Certificate No. 05103



ISO 14001  
Certificate No. 7116



ISO 9001 : 2000  
Certificate No. 550-1559-04-002-04

## Packing Specification of 52mm Ammo Pack

- The method of inner box packing is shown in figure 1.
- Dimension and Quantity of inner box and taping.

Product outline	A	B	C	Quantity	b	c	f	g	h	$l_1 \sim l_2$	m
DO-34	262 mm	77 mm	71 mm	5kpcs/box	52.25 ±0.25 mm	6.25 ±0.25 mm	5.00 ±0.30 mm	1.0 mm max.	1.0 mm max.	1.0 mm max.	0.8 mm max.

### 3. Carton Dimension

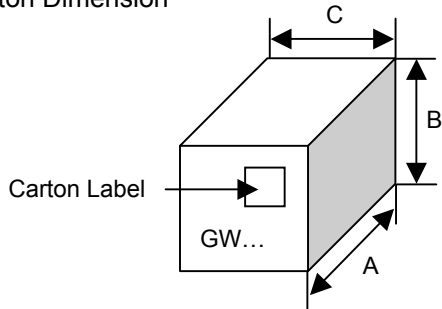

Product outline		DO-34
Dimension	A(mm)	404
	B(mm)	273
	C(mm)	165

- 10 box / carton
- 5 box / layer
- 2 layer / carton

### 4. Quantity of Carton Pack.

Product outline	DO-34
Quantity	50kpcs

### 5. Label

5.1 The information of inner box label must be listed:

- 5.1.1 TYPE
- 5.1.2 QTY
- 5.1.3 CODE
- 5.1.4 RMK

5.2 The information of carton label must be listed:

- 5.2.1 TYPE
- 5.2.2 QTY

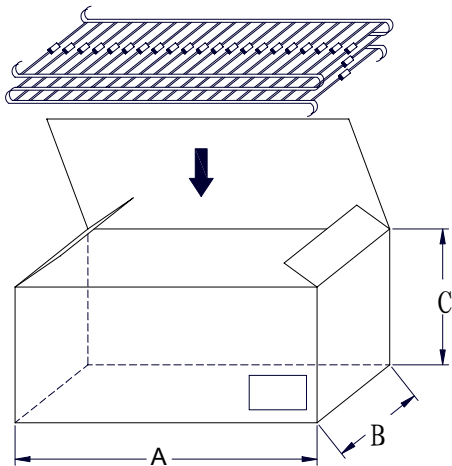
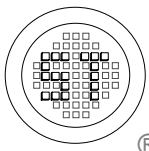
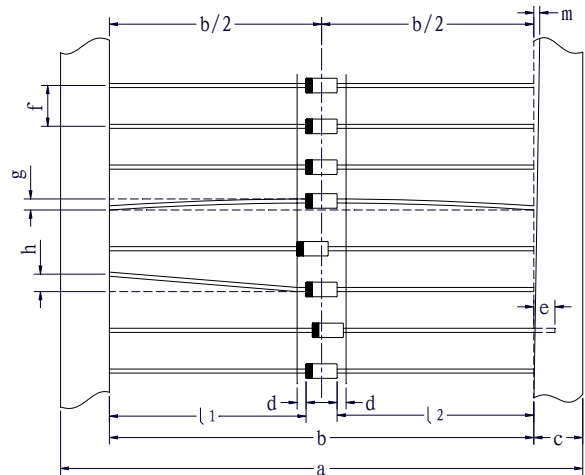
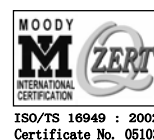

figure 1



**SEMTECH ELECTRONICS LTD.**

(Subsidiary of Semtech International Holdings Limited, a company listed on the Hong Kong Stock Exchange, Stock Code: 724)



ISO/TS 16949 : 2002  
Certificate No. 05103



ISO 14001  
Certificate No. 7116



ISO 9001 : 2000  
Certificate No. 550-1559-04-002-04