

Manganese Lithium Coin Batteries (ML series): Individual Specifications

ML616S

Dimensions(mm)

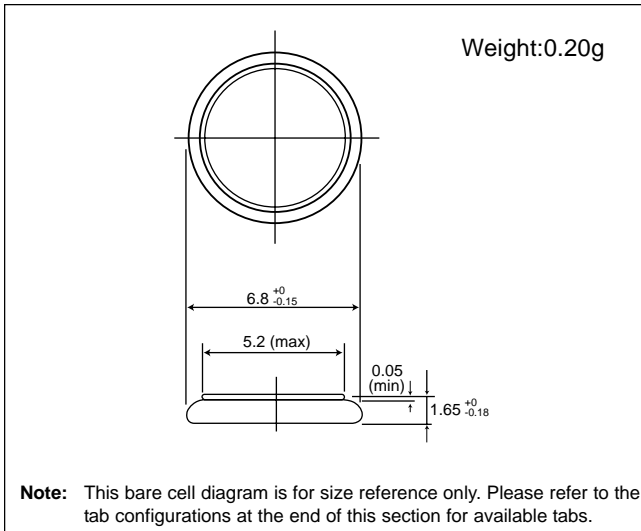

Specification

Nominal voltage (V)	3
Nominal capacity (mAh)	2.9
Continuous standard load (mA)	0.01
Operating temperature (C)	-20 ~ +60

Discharge characteristics

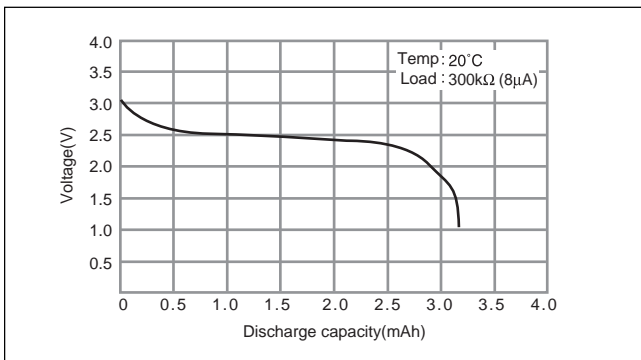

Consumption current vs. Duration time

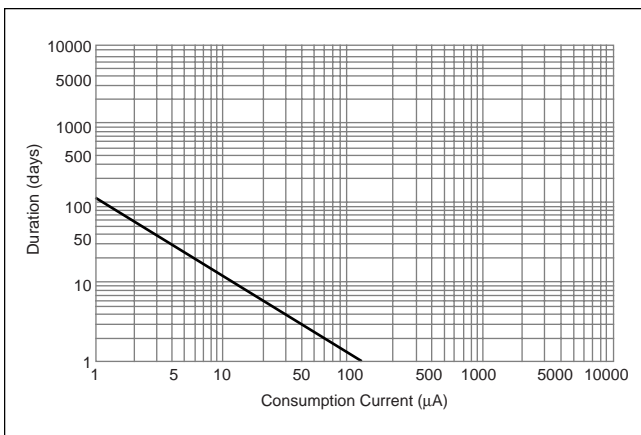

ML621S

Dimensions(mm)

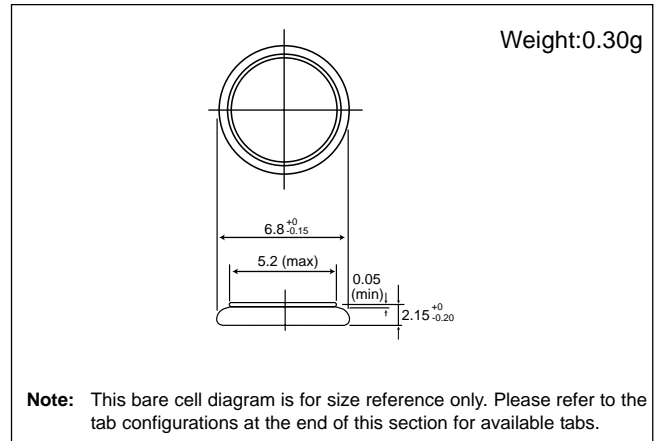

Specification

Nominal voltage (V)	3
Nominal capacity (mAh)	5
Continuous standard load (mA)	0.01
Operating temperature (C)	-20 ~ +60

Discharge characteristics

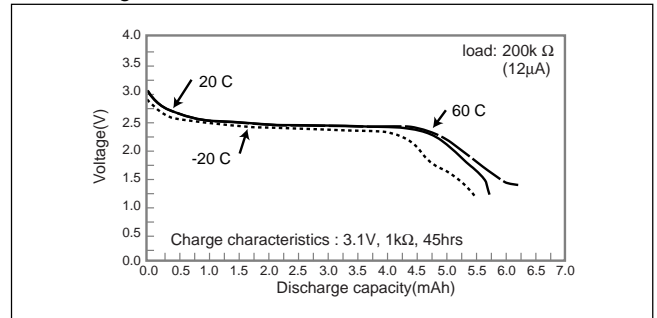

Charge characteristics

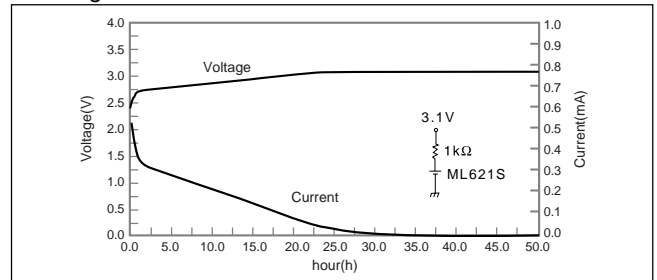

Consumption current vs. Duration time

