

KLS3-LPT-48*10L-L65MM

Externally driven piezo buzzers



Compact size



Low power consumption



High reliability



Easy integration

◆ Technical terms

No.	Technical terms	Value	Unit
1	Rated Voltage	12	Vp-p
2	Drive Voltage, Continuous	40	Vp-p
3	Drive Voltage, Intermittent	55	Vp-p
4	*Rated Current	≤100	mA
5	*Rated Current	120000±30%	pF
6	*Sound Output at30cm	≥95	dB
7	Resonance Frequency	3.0±0.5	KHz
8	Operating Temperature	-40 ~ +100	°C
9	Storage Temperature	-40 ~ +100	°C
10	Weight	2	g
11	RoHS	Yes	-

*Applying rated voltage (at 3.0KHz, ½ duty , square wave)

*Test Basic State: Temp(20±2°C),Humidity(40~70%RH),Air pressure(860~1060hPa).

◆ DIMENSIONS (UNIT: mm) Tolerance: ±0.5mm Except Specified

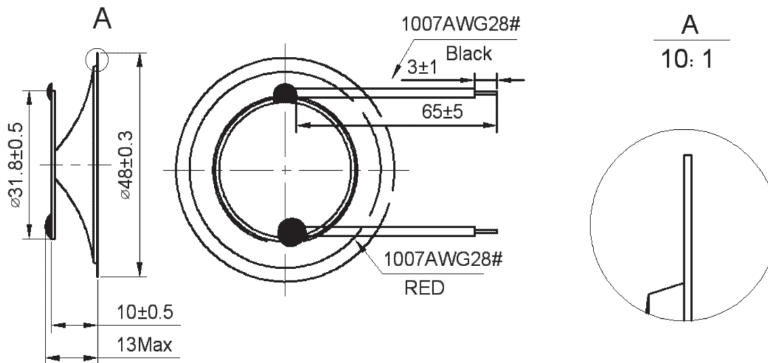

◆ Application Areas

Reverse radar / parking assist prompt (integrated into instrument panel in some models).
The frequency rises as distance shortens; continuous tone indicates close-range warning.